

793F

Mining Truck



Engine

Engine Model	Cat® C175-16	
Gross Power – SAE J1995	1976 kW	2,650 hp
Net Power – SAE J1349	1848 kW	2,478 hp

Operating Specifications

Nominal Payload Capacity	226.8 tonnes 250 tons
Gross Machine Operating Weight	386 007 or 390 089 kg (851,000 or 860,000 lb)

793F Features

High Performance Engine

The Cat® C175-16 engine offers you the perfect balance between power, robust design and economy.

Enhanced Serviceability

Improved serviceability points and grouped service locations mean your truck spends more time on the haul road than in the shop.

Power Shift Transmission

A smooth shifting six speed transmission using ECPC gives operators a comfortable ride, constant power and improved fuel efficiency.

Reliable Mechanical Drive System

The 793F's power train gives you the fastest truck on steep grades, poor underfoot conditions and on haul roads with high rolling resistance.

Robust Braking

Cat oil-cooled, multiple disc brakes on all four corners offer you exceptional, fade-resistant braking.

Comfortable Cab

Operators find the large, spacious cab offers unmatched visibility and exceptional comfort.

Truck Body

A variety of Caterpillar designed and built bodies provide you optimal performance and reliability.

Contents

Power Train – Engine	4
Power Train – Transmission	5
Power Train Options	6
Engine/Power Train Integration.....	7
Cat Braking Systems	8
Structures.....	9
Truck Body Systems	10
Monitoring System.....	11
Operator's Station	12
Customer Support.....	14
Serviceability	15
Safety	16
Sustainability	17
Specifications.....	18
Standard Equipment.....	26
Optional Equipment.....	27





Whether you're hauling copper, coal, gold, iron ore or overburden the 793F provides you with the best in class cost per unit of production. Including the improvements in safety, productivity, serviceability and comfort you will see why the 793F is the industry leader of its class. Combine these features with unmatched dealer support and you will see why more mine sites choose Cat Mining Trucks for their production needs.

Power Train – Engine

Power, reliability and efficiency for your most demanding mining applications.

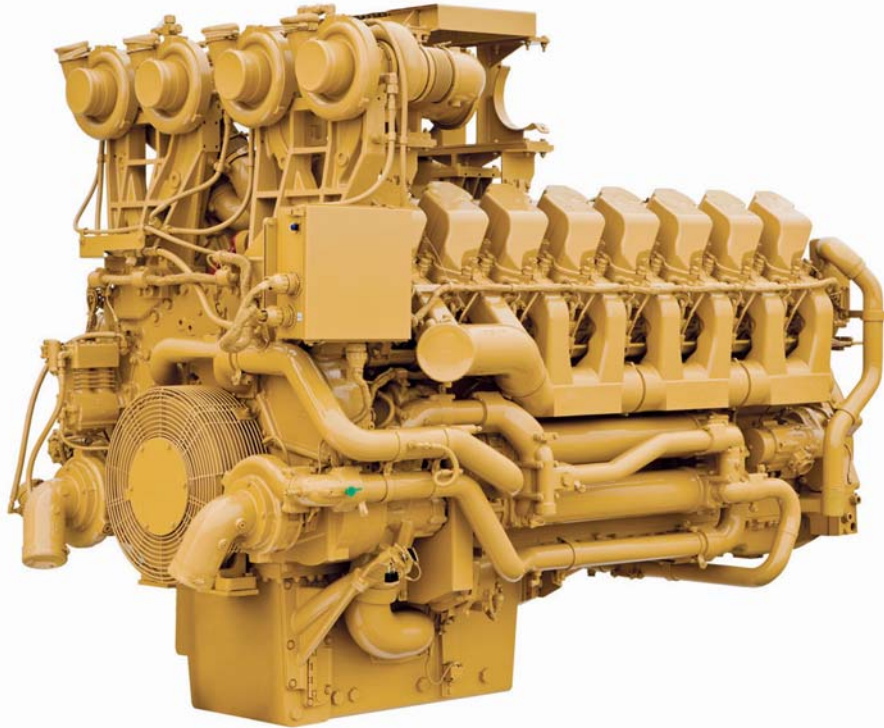

Cat® C175-16 Engine

The 793F has a Cat C175-16 quad turbocharged air-to-air aftercooled diesel engine that has enhanced power management capability for maximum hauling performance in your most demanding mining applications.

- The C175-16 is a 16-cylinder, four-stroke design that uses long, effective power strokes for optimum efficiency.
- Is compliant with U.S. Environmental Protection Agency emission requirements.
- The 20 percent net torque rise of the C175-16 provides unequalled lugging force during acceleration on steep grades and in rough underfoot conditions. Torque rise effectively matches transmission shift points for maximum efficiency and fast cycle times.
- High displacement, low rpm rating and conservative horsepower ratings mean more time on the haul roads and less time in the shop.
- The Cat Common Rail Fuel System is an electronically-controlled system senses operating conditions and regulates fuel delivery for optimum fuel efficiency. This precise and flexible fuel system gives the engine the ability to meet emission regulations without sacrificing performance, reliability or durability.
- The flexible core design of the MESABI radiator means easier serviceability along with long life and high durability.
- You have two starter options: The tank on the standard air start system is ground level serviceable, while the electric start option allows the air system to be totally removed from the truck.

Power Train – Transmission

More power to the ground means greater productivity for you.

Mechanical Power Train

The 793F gives you the fastest truck on grade in its class. The Cat mechanical drive power train and power shift transmission provides you unmatched operating efficiency and control on steep grades, in poor underfoot conditions and on haul roads with high rolling resistance.

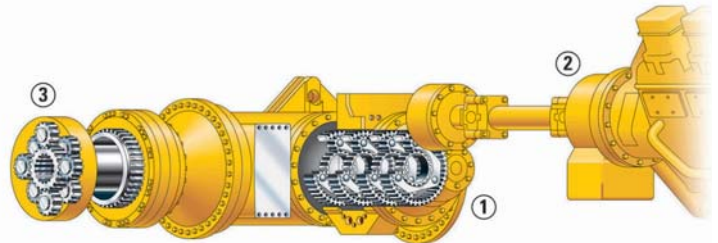

1 – Transmission with Electronic Clutch Pressure Control

The Cat six-speed planetary power shift transmission is matched with the direct-injection C175-16 diesel engine to deliver constant power over a wide range of operating speeds.

The proven planetary power shift transmission is built tough and is designed for the higher power of the C175-16 engine.

A dedicated oil tank and circuit provides cooler, cleaner oil for maximum performance and longer component life.

Electronic Clutch Pressure Control (ECPC) provides maximum performance, smooth shifting, long clutch life and a more comfortable ride.

2 – Lock-Up Torque Converter

Combines maximum rimpull and cushioned shifting of torque converter drive with the efficiency and performance of direct drive. The lock-up torque converter engages at approximately 8 km/h (5 mph), delivering more power to the wheels.

3 – Final Drives

Cat final drives work as a system with the planetary power shift transmission to deliver maximum power to the ground. Built to withstand the forces of high torque and impact loads, double reduction final drives provide high torque multiplication to further reduce drive train stress.



Power Train Options

Two power train options to match your applications/conditions.

Extended Life Wheel Stations

Developed for uphill hauling applications, this arrangement is designed to extend wheel life and hauling performance on long, uphill hauls. Extended life wheel stations are built with larger, more durable components, including larger spindles, wider wheel bearing spacing, a larger braking surface and additional discs in the front for longer brake life and more time between overhauls.

Additional Retarding

Developed for downhill-loaded applications, this option typically delivers an extra gear of retarding capability or 25 percent more speed on downhill grades. Additional retarding is achieved by adding larger brakes and additional brake cooling capability. This option requires the use of Extended Life Wheel Stations.

Engine/Power Train Integration

Reduced operating costs through electronically combined power train components.

Cat Data Link

Reduces operating costs through electronically integrating machine computer systems to optimize overall power train performance, increase reliability and component life.

Controlled Throttle Shifting

Regulates engine rpm during shifting to reduce power train stress and clutch wear by controlling engine speed, torque converter lock-up and transmission clutch engagement for smoother shifts and longer component life.

Directional Shift Management

Regulates engine speed during directional shifts to prevent damage caused by high speed, directional changes.

Body-Up Shift Inhibitor

Prevents the transmission from shifting above the pre-programmed gear without the body fully lowered.

Overspeed Protection

The transmission control electronically senses engine conditions and automatically up-shifts one gear to prevent overspeeding. If overspeeding occurs in top gear, the lock-up clutch is disengaged.

Programmable Top Gear

Transmission top gear maximum can be set using the Cat ET service tool to help the operator maintain speed limits.

Downshift Inhibitor

Prevents engine overspeeding by keeping the transmission from downshifting until engine speed reaches the downshift point.

Rapid Downshift Function

Does not allow a turnaround shift until approximately 2.3 seconds after a shift occurs.

Reverse Speed Inhibitor

Prevents shifts into reverse when forward ground speeds are in excess of 5 km/h (3 mph).



Cat Braking Systems

Superior braking control lets operators focus on productivity.



Integrated Braking System

Reliable performance and control in extreme haul road conditions is important for operator safety. The Cat oil-cooled braking system provides this. Integrated systems combine the service, secondary, parking brakes and retarding functions for optimum braking efficiency that does not burn fuel while retarding.

Oil-Cooled Multiple Disc Brakes

Cat four-wheel, forced oil-cooled, multiple disc service brakes are continuously cooled by water-to-oil heat exchangers for exceptional, non-fading braking and retarding performance.

Brake Design

Cat oil-cooled disc brakes are designed with large discs and plates for reliable, adjustment-free operation and performance. Brakes are completely enclosed and sealed to prevent contamination and reduce maintenance.

Long Life

An oil film prevents direct contact between the discs. This design absorbs the braking forces by shearing the oil molecules and carrying heat away to extend brake life.

Parking Brake

Oil-cooled, spring-applied, hydraulically released parking brake is applied to all four wheels for superior parking capability on all grades up to 15 percent.

Hydraulic Automatic Retarder Control (ARC)

Hydraulically activated, automatic retarder control system electronically controls retarding on grade to maintain optimum engine rpm and brake system performance. ARC is now adjustable in each gear.

Structures

Superior Cat structures in the 793F give you durability and long life.



Box Section Design

The 793F frame uses a box-section design, incorporating two forgings and 14 castings in high stress areas with deep penetrating and continuous wrap-around welds to resist damage from twisting loads without adding extra weight.

- **Steel Structures** – Mild steel used throughout frame provides flexibility, durability and resistance to impact loads, even in cold climates and allows for easy field repairs.
- **Castings** – Castings have large radii with internal reinforcing ribs to dissipate stress in areas of high stress concentration. Castings move welds to lower stress areas for greater frame life.

Integral Four-Post ROPS Cab

Resiliently mounted to the main frame to reduce vibration and sound, the integral ROPS is designed as an extension of the truck frame.

Suspension System

Designed to dissipate haul road and loading impacts for longer frame life and a more comfortable ride.

- **Durable Design** – Rugged cylinders utilize large diameter bore and low pressure nitrogen/oil design for long life with minimal maintenance.
- **Front** – Front cylinders with preset caster and camber are mounted to the frame and serve as steering kingpins for a tight turning radius with excellent maneuverability and low maintenance.
- **Rear** – Rear cylinders allow axle oscillation and absorb bending and twisting stresses caused by uneven and rough haul roads rather than transmitting them to the main frame.

Four-bar Link Rear Suspension

The Four-bar Link Suspension directs stress to be more evenly distributed than an A-frame design and allows more service area around the transmission.

Steering System

Hydraulic steering control system is designed for exceptional smoothness and precise control. A separate circuit prevents cross contamination for long life.

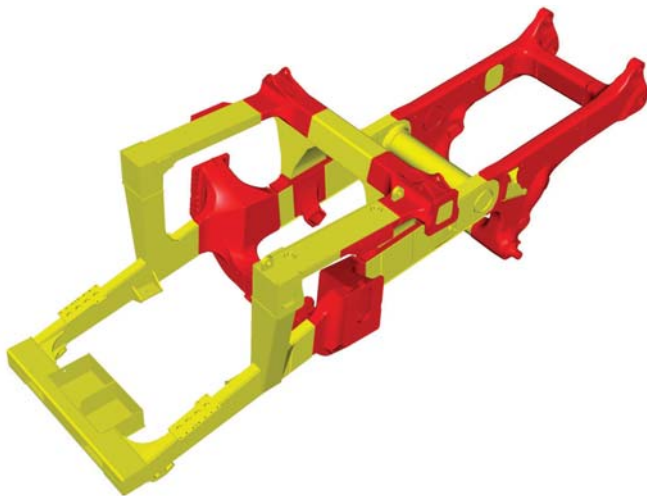

Yellow – Fabrications, Red – Castings

Truck Body Systems

Designed and built for rugged performance and reliability.

Cat Truck Bodies

You have three body options with the 793F: X Body, MSD II (Mine Specific Design) and Gateless Coal Body. These bodies are specifically designed to work with the Cat frame for superior structural performance.

1 – X Body

If you have a new mine or are a contract miner the X Body is designed for you. It uses the Cat Mine Specific Design process to create a body that is properly sized and configured to meet the specific requirements of heavy-duty applications. The X Body design offers a larger volume with no weight penalty.

2 – MSD II

The MSD II bodies are intended for established mines and are customized to suit your specific mining applications based on a mine site evaluation. The MSD II is the best lightweight body ever built for mining applications and achieves excellent payload performance.

3 – Gateless Coal Body

The Gateless Coal Body is intended for dedicated coal haulage applications. It can be loaded to achieve target payload across the full range of coal densities. The body is designed and built using the MSD II Body concept, ensuring superior durability and reliability.

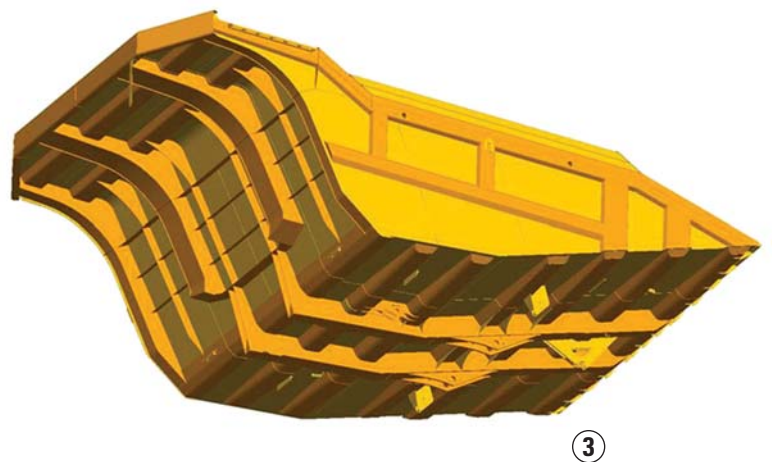
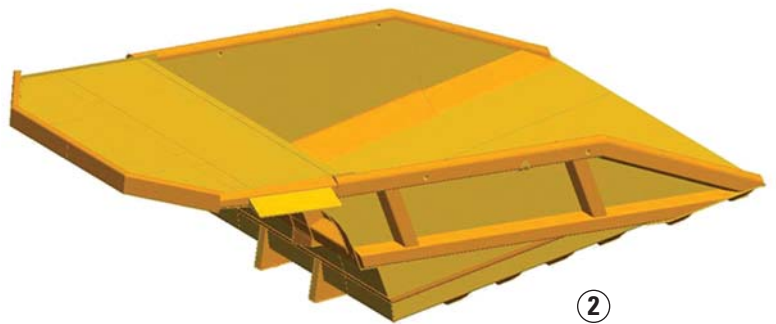
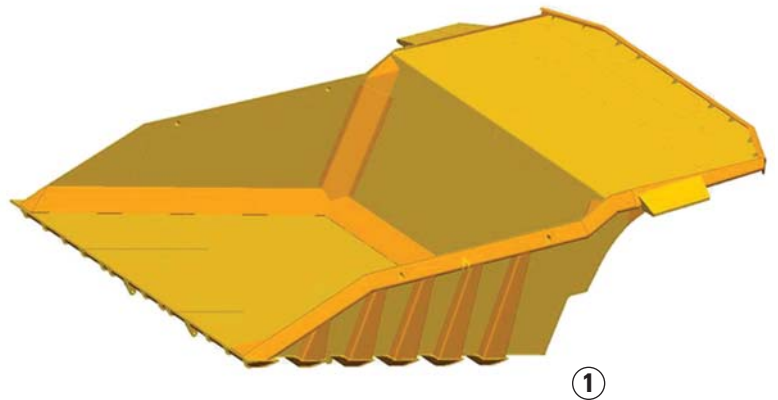

Monitoring System

Keeping your production at peak levels.



VIMS™ 3G Monitoring System

The third generation VIMS monitoring system provides you with critical health and payload data in real-time to keep the 793F performing at top production levels. Data from VIMS can be used to lower your operating costs by improving the effectiveness of scheduled maintenance programs improve machine availability and improve the effectiveness of scheduled maintenance programs. Sensors throughout the machine enable VIMS to quickly exchange and monitor information from all systems. Users can view up to 10 different machine parameters at a time. Your service technicians can quickly download data by connecting directly to the system or through its own web address and generate reports in the office, shop or cab.

Production and Payload Management

Information is available to monitor and enhance truck/loading tool effectiveness, improve fleet productivity and help extend the life of truck frames, tires, rims and power train components, while lowering your operating and maintenance cost.

External Payload Indicators

External lights signal loading tool operators when to cease loading for optimum payloads without overloading. Optional payload displays with digital numeric monitor are available.

Road Analysis Control

Optional system monitor your haul road conditions by measuring frame rack, bias and pitch to improve cycle times, frame life, tire life and fuel efficiency.

VIMSpC

An Off-board software reporting program that allows your service personnel to download a complete record of machine health and productivity data. Health and payload reports can be generated for more effective machine management, which reduces downtime and lowers operating costs.

Advisor Display

The Advisor display provides real-time machine performance and basic trip, maintenance and diagnostic data. Various machine parameters can be viewed on the display including coolant temperature, oil pressure, current gear selection, current payload and more.

VIMS Supervisor

Optional software allows your mine personnel to easily manage and interpret VIMS data for optimum fleet management and productivity.



Operator's Station

Ergonomically designed for all-day comfort, control and productivity.

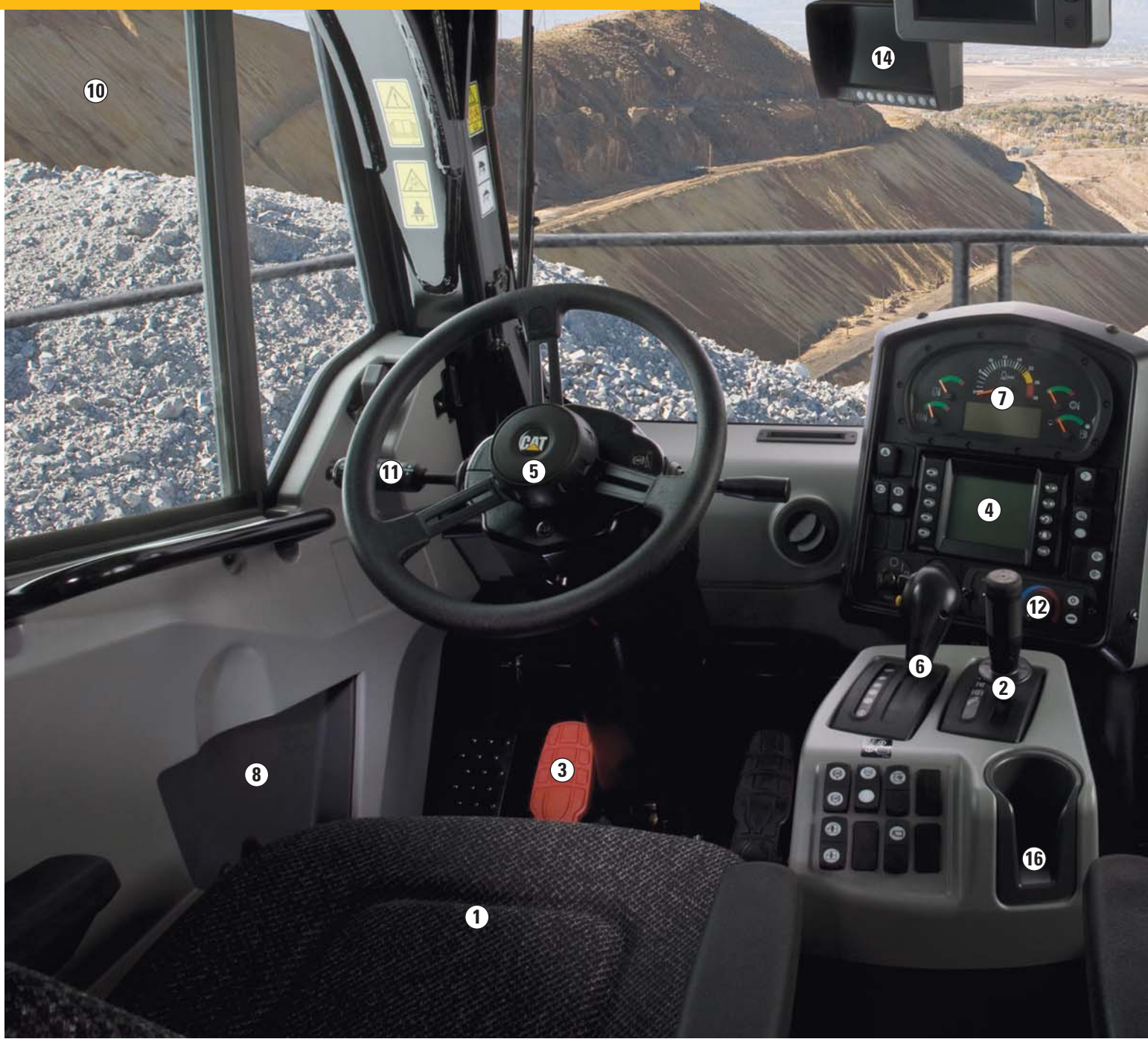



Operator Environment

You now have the choice to select a cab with the features you desire. There are three choices based on popular arrangements. Available offerings include a Standard Cab, Deluxe Cab or Deluxe Cold Weather Cab.

Ergonomic Layout

To minimize operator fatigue and maximize productivity the all new F Series operator station is ergonomically designed for total machine control in a comfortable, productive and safe environment. Controls, levers, switches and gauges are positioned for ease of use.

Viewing Area

Designed for excellent all-around visibility and clear sight lines to the haul road, the large viewing area offers exceptional visibility, allowing the operator to maneuver with confidence for high productivity. The air cleaners have been relocated to the front of the truck, allowing the operator increased visibility.

- 1) Air Suspension Seat with Three-Point Operator Restraint
- 2) Hoist Lever
- 3) Secondary Brake Pedal
- 4) Monitoring System
- 5) Steering Column
- 6) Transmission Console
- 7) Gauges
- 8) Storage Compartment
- 9) Trainer Seat
- 10) Operator Window
- 11) Operator Controls
- 12) Heating/Air Conditioning
- 13) Four-Post ROPS
- 14) Camera System Monitor (optional)
- 15) MineStar Monitor (optional)
- 16) Cup Holder
- 17) Dome Courtesy Lights

Customer Support

Keeping you running with the most experienced dealer network.

Commitment Makes the Difference

Cat dealers offer a wide range of solutions, services and products that help you lower costs, enhance productivity and manage your operation more efficiently. From the time you select a piece of Cat equipment until the day you trade or sell it, the support you get from your Cat dealer makes the difference.

Dealer Capability

Cat dealers provide the level of support you need, on a global scale. Dealer expert technicians have the knowledge, experience, training and tooling necessary to handle your repair and maintenance needs, when and where you need them.

Product Support

When Cat products reach the field, they are supported by a worldwide network of parts distribution facilities, dealer service centers and technical training facilities to keep your equipment up and running. Cat customers rely on prompt, dependable parts availability through our global dealer network, ready to meet your needs 24/7.

Service Support

Every piece of Cat equipment is designed and built to provide maximum productivity and operating economy throughout its working life. Cat dealers offer a wide range of service plans that will maximize uptime and return on your investment, including:

- Preventive Maintenance Programs
- Diagnostic Programs, such as Scheduled Oil Sampling and Technical Analysis
- Rebuild and Reman Option
- Customer Support Agreements

Operation

Your Cat dealer can arrange training programs to help operator's improve productivity, decrease downtime, reduce operating costs and enhance safety.



Application Awareness

Operating and maintenance costs are influenced by many application and site-specific factors, such as: material density, loading position, payload, grades, speeds, haul road design and maintenance. Your Cat dealer can provide you with an understanding of the effects application characteristics and operating techniques have on maintenance and operating costs.

Serviceability

Reduced maintenance time results in more productivity.

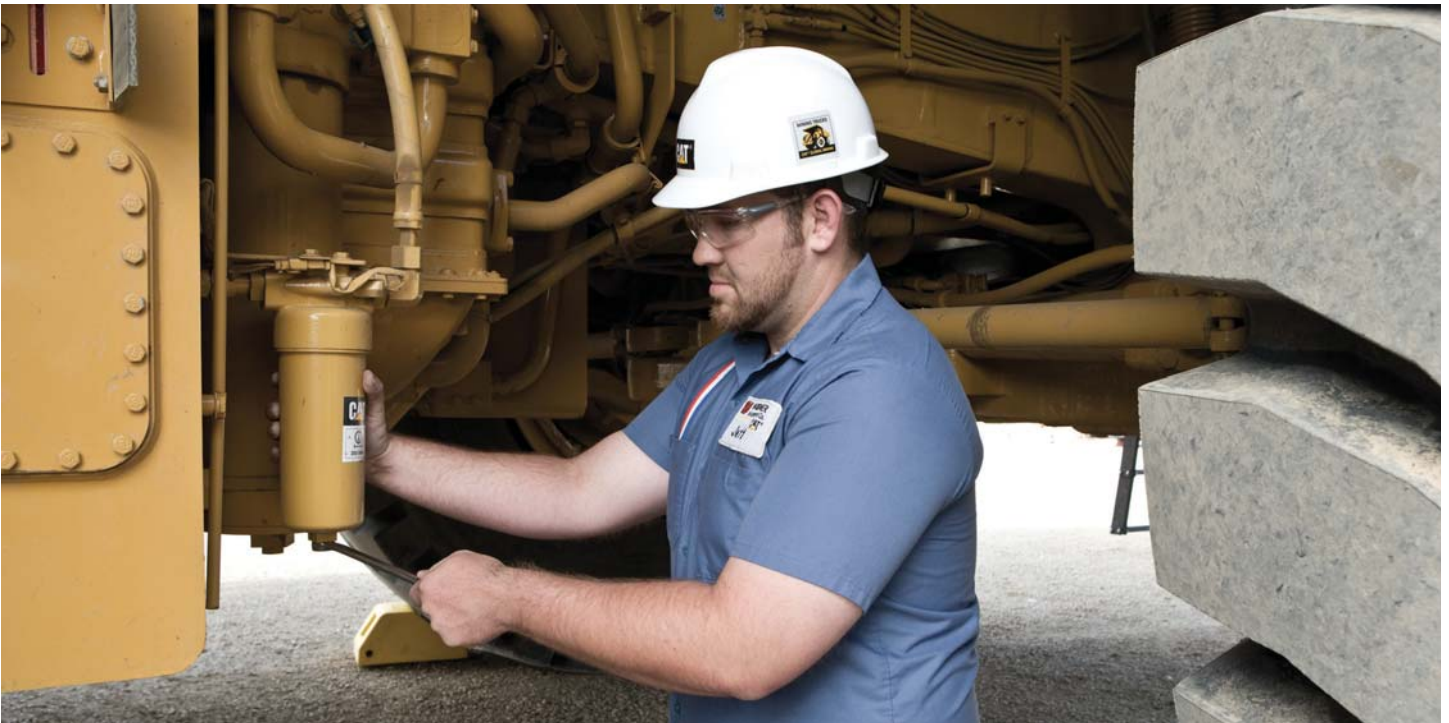

Servicing Ease

Easy access to daily service points simplifies servicing and reduces your time spent on regular maintenance procedures. Enhanced serviceability and long service intervals are designed to increase machine availability and productivity.

In-Frame Access

Gives you easy access to major components for easy servicing and removal.

Ground Level Access

Grouped ground level points allow you convenient servicing of tanks, filters, drains, batteries, AutoLube system, pressure taps, screens, fluid sight gauges and engine shutdown. Ground level VIMS data port permits easier downloading of information.

AutoLube

Automatic lubrication system reduces your maintenance time by automatically lubricating necessary components on a regular basis.

Scheduled Oil Sampling

S-O-SSM sampling valves speed sampling and analysis reliability.

Pressure Test Points

Disconnect valves are conveniently located throughout the hydraulic systems for easy pressure testing.

Sealed Electrical Connectors

Electrical connectors are sealed to lock out dust and moisture. Harnesses are braided for protection. Wires are color-coded for easy diagnosis and repair.

Safety

Designed with safety as the first priority.

Product Safety

Caterpillar is concerned about your safety and has been and continues to be proactive in developing mining machines that meet or exceed safety standards. Safety is an integral part of all machine and system designs.

Cat Detect System

Knowing what's around your 793F at all times is important. The Cat Detect system is factory installed as standard equipment on 793F Mining Trucks. The full Cat Detect system, RADAR AND CAMERA, provides both audible and visual indications of detected objects. This system uses a combination of short and medium range radars which surround the machine, along with cameras on each side to allow the operator to confirm the detected object. The cameras supplement the radar alerts and are selectable by touch screen menus through an intuitive interface.

Integral ROPS Cab

Resiliently mounted to the main frame to reduce vibration and sound, the integral ROPS structure is an extension of the truck frame and exceeds SAE requirements.

Access/Egress

Improvements for machine level access and egress include a standard 600 mm (24 in) diagonal stairway across the front of the machine. Improvements for ground level access include an optional powered access stairway.

Brake Systems

Four corner oil braking system provides excellent control in slippery conditions. The system assures braking in the event of complete hydraulic failure.

Overload Policy

Safety is integral to maintaining the highest productivity in mining operations. The Caterpillar 10/10/20 Overload Policy assures that steering and braking systems have sufficient capacity to perform, even at 20 percent overload.



Other Safety Features

- Slip resistant surfaces
- 76 mm (3 in) wide orange three-point operator restraint
- Wide angle mirrors
- Body raised indicator
- Double body retaining cables
- Guard rails
- Reverse neutralizer when dumping
- Low interior sound level

Isolation Box

Lockout tagout box mounted on front bumper includes engine shutdown switch, battery lockout, starter lockout and transmission lockout.

SAFETY.CAT.COM™

Sustainability

A variety of features improve sustainability in areas of decreasing waste, extending component life and lowering emissions levels.



Sustainability Features

The 793F Mining Truck offers continuous rear axle filtration, extended life filters and extended maintenance intervals, which aid in decreasing the amount of waste contributed to our environment.

Engines with Advanced Technology

Engines with advanced technology contribute fewer emissions to the environment while maintaining fuel efficiency.

Advanced Surface Technology (AST)

Advanced Surface Technology (AST) is a replacement for hard chrome coatings on some steel parts, including suspension and hoist cylinder rods. This technology improves wear resistance and reduces repair time. Chrome has been eliminated to reduce environmental impact.

Fuel Efficiency

The engine provides additional retarding by running against compression on downhill hauls. During retarding applications the engine ECM does not inject fuel into the cylinders for exceptional fuel economy.

793F Mining Truck Specifications

Engine

Engine Model	Cat C175-16	
Gross Power – SAE J1995	1976 kW	2,650 hp
Net Power – SAE J1349	1848 kW	2,478 hp
Torque Rise	20%	
Bore	175 mm	6.9 in
Stroke	220 mm	8.7 in
Displacement	85 L	5,187 in ³

- Power ratings apply at 1,750 rpm when tested under the specified condition for the specified standard.
- Ratings based on SAE J1995 standard air conditions of 25° C (77° F) and 99 kPa (29.61 Hg) dry barometer. Power based on fuel having API gravity of 35 at 16° C (60° F) and an LHV of 42.780 kJ/kg (18,390 Btu/lb) when engine used at 30° C (86° F).
- No engine derating required up to 3353 m (11,000 ft) altitude.
- EPA Compliant. Where applicable, the Cat C175-16 engine is compliant with U.S. Environmental Protection Agency emission requirements.

Weights – Approximate

Chassis Weight	122 300 kg	270,000 lb
Body Weight Range	26 862- 47 627 kg	59,220- 105,000 lb

- Chassis weight with 100 percent fuel, hoist, body mounting group, rims and 40.00R57 tires.
- Body weight varies depending on how body is equipped.

Operating Specifications

Nominal Payload Capacity	226.8 tonnes	250 tons
Top Speed – Loaded	60 km/h	37.3 mph
Steer Angle	36 Degrees	
Turning Diameter – Front	28 m	93 ft
Turning Circle Clearance Diameter	33 m	107 ft
Gross Machine Operating Weight	386 007 or 390 089 kg	851,000 or 860,000 lb

- Refer to the Cat Mining Truck 10/10/20 Overload Policy for maximum gross machine weight limitations.

Final Drives

Differential Ratio	1.8:1	
Planetary Ratio	16:1	
Total Reduction Ratio	28.8:1	

Transmission

Forward 1	12.9 km/h	8 mph
Forward 2	17.4 km/h	10.8 mph
Forward 3	23.8 km/h	14.8 mph
Forward 4	32.1 km/h	19.9 mph
Forward 5	43.6 km/h	27.1 mph
Forward 6	60 km/h	37.3 mph
Reverse	11.8 km/h	7.3 mph

Suspension

Effective Cylinder Stroke – Front	130.5 mm	5.1 in
Effective Cylinder Stroke – Rear	105.5 mm	4.2 in
Rear Axle Oscillation	±4.9 degrees	

Body Hoists

Pump Flow – High Idle	846 L/min	224 gal/min
Relief Valve Setting – Raise	20 370 kPa	2,955 psi
Body Raise Time – High Idle	19 Seconds	
Body Lower Time – Float	20 Seconds	
Body Power Down – High Idle	17.5 Seconds	

- Twin, two-stage hydraulic cylinders mounted outside main frame, double-acting cylinders in second stage.
- Power raise in both stages, power down in second stage.
- Automatic body lower modulation reduces impact on frame.

Brakes

Outside Diameter	874.5 mm	34.5 in
Brake Surface – Front	89 817 cm ²	13,921 in ²
Brake Surface – Rear	34 500 cm ²	20,847 in ²
Standards	J-ISO 3450 JAN88, ISO 3450:1996	

Weight Distributions – Approximate

Front Axle – Empty	48%	
Rear Axle – Empty	52%	
Front Axle – Loaded	33%	
Rear Axle – Loaded	67%	

Capacity – MSD II – 100% Fill Factor

Struck	112-142 m ³	146-186 yd ³
Heaped (SAE 2:1)	159-190 m ³	209-250 yd ³

- Contact your local Cat dealer for body recommendation.

Service Refill Capacities

Fuel Tank	2839 L	750 gal
Fuel Tank (optional)	4922 L	1,300 gal
Cooling System	1074 L	284 gal
Crankcase	312 L	82 gal
Rear Axle Housing	984 L	260 gal
Steering System (Includes Tank)	290 L	77 gal
Brake/Hoist System (Includes Tank)	1315 L	347 gal
Torque Converter/Transmission Sump	102 L	27 gal
Torque Converter/Transmission System (Includes Sump)	209 L	55 gal

ROPS

ROPS Standards

- ROPS (Rollover Protective Structure) for cab offered by Caterpillar meets ISO 3471:1994 ROPS criteria.
- FOPS (Falling Objects Protective Structure) meets ISO 3449:1992 Level II FOPS criteria.

Sound

Sound Standards

- The operator sound pressure level measured according to work cycle procedures specified in ISO 6394 and 6396 is 76 dB(A) for cab offered by Caterpillar, when properly installed and maintained and tested with doors and windows closed.
- Hearing protection may be needed when operating with an open operator station and cab (when not properly maintained or doors/windows open) for extended periods or in a noisy environment.

Steering

Steering Standards

SAE J15111 OCT90,
ISO 5010:1992

Weight/Payload Calculation

(Example)

	793F, SLWS, 29", 40R57*		793F, XLWS, 29", 40R57		793F, XLWS, 32", 50/80R57**	
	MSD Body		MSD Body		MSD Body	
	kg	lb	kg	lb	kg	lb
Truck Body MSD II (209 yd ³ /160 m ³)						
Gross Machine Operating Weight	386 008	851,000	386 008	851,000	390 090	860,000
Basic Machine Weight ¹	42 638	94,001	42 638	94,001	42 638	94,001
Attachments	78 956	174,068	81 463	179,595	85 145	187,712
Body Weight – Fully Lined MSD II (230 yd ³ /160 m ³)	33 102	72,977	33 102	72,977	33 102	72,977
Operating Machine Weight	154 766	341,200	157 273	346,727	165 783	365,489
3% Debris Allowance ²	4643	10,238	4718	10,404	4829	10,647
Empty Operating Machine Weight (EOMW) ¹	159 409	351,436	161 991	357,129	165 783	365,489
	Tonnes	Tons	Tonnes	Tons	Tonnes	Tons
Potential Target Payload ³	227	250	224	247	225	247

*793F Standard includes: common arrangement, 100% fuel (2,840 L/750 gal), hoist, body mounting group, mandatory attachments, standard wheel station, 29" rims and 40.00R57 Tires.

**793F XLWS includes: common arrangement, 100% fuel (2,840 L/750 gal), hoist, body mounting group, mandatory attachments, extended life wheel station, 32" quick change rims and 50/80R57 Tires.

¹ Weights will vary dependent on configuration and may include \pm 2% variation due to standard material tolerances.

² Calculations include (3% OMW) debris allowance. However, actual debris allowance should be considered based upon known site conditions.

³ It is recommended to work with your Global Mining representative to calculate target payload per specific site.

Caterpillar recommends the customer evaluate all job conditions and consult the Cat dealer and tire manufacturer for proper tire selection. Reference tire limitations with your local tire distributor concerning details of the tires being considered.

Productive capabilities of the 793F are such that, under certain job conditions, TKPH (TMPH) capabilities of standard or optional tires could be exceeded and, therefore, limit production.

793F Mining Truck Specifications

Dimensions

All dimensions are approximate.

Shown with 176 m³ (230 yd³) MSD II Body.

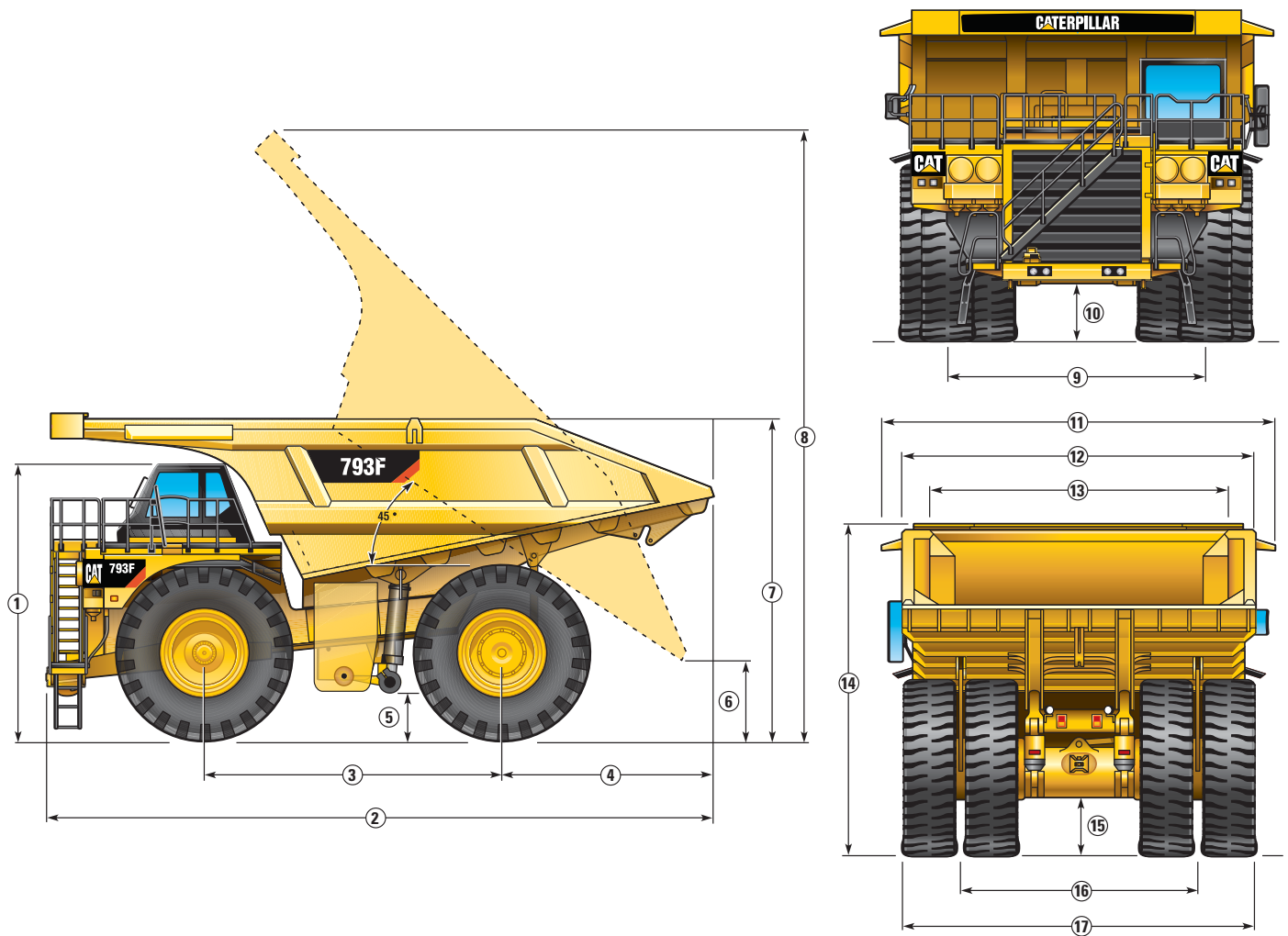

1 Height to Top of ROPS	5597 mm	18 ft 4 in
2 Overall Length	13 702 mm	44 ft 11 in
3 Wheelbase	5905 mm	19 ft 5 in
4 Rear Axle to Tail	4257 mm	13 ft 11 in
5 Ground Clearance	990 mm	3 ft 3 in
6 Dump Clearance	1301 mm	4 ft 3 in
7 Loading Height – Empty	6533 mm	21 ft 5 in
8 Overall Height – Body Raised	13 878 mm	45 ft 6 in
9 Centerline Front Tire Width	5630 mm	18 ft 6 in
10 Engine Guard Clearance	1217 mm	4 ft 0 in
11 Overall Canopy Width	8295 mm	27 ft 3 in
12 Outside Body Width	7626 mm	25 ft 0 in
13 Inside Body Width	6946 mm	22 ft 9 in
14 Front Canopy Height	6603 mm	21 ft 8 in
15 Rear Axle Clearance	1006 mm	3 ft 4 in
16 Centerline Rear Dual Tire Width	4963 mm	16 ft 3 in
17 Overall Tire Width	7605 mm	24 ft 11 in

793F Gradeability/Speed/Rimpull*

To determine gradeability performance: Read from gross weight down to the percent of total resistance. Total resistance equals actual percent grade plus 1% for each 10 kg/t (20 lb/ton) of rolling resistance. From this weight-resistance point, read horizontally to the curve with the highest obtainable gear, then down to maximum speed. Usable rimpull will depend upon traction available and weight on drive wheels.

- Typical Field Empty Weight
- Gross Machine Operating Weight
390 089 kg (860,000 lb)

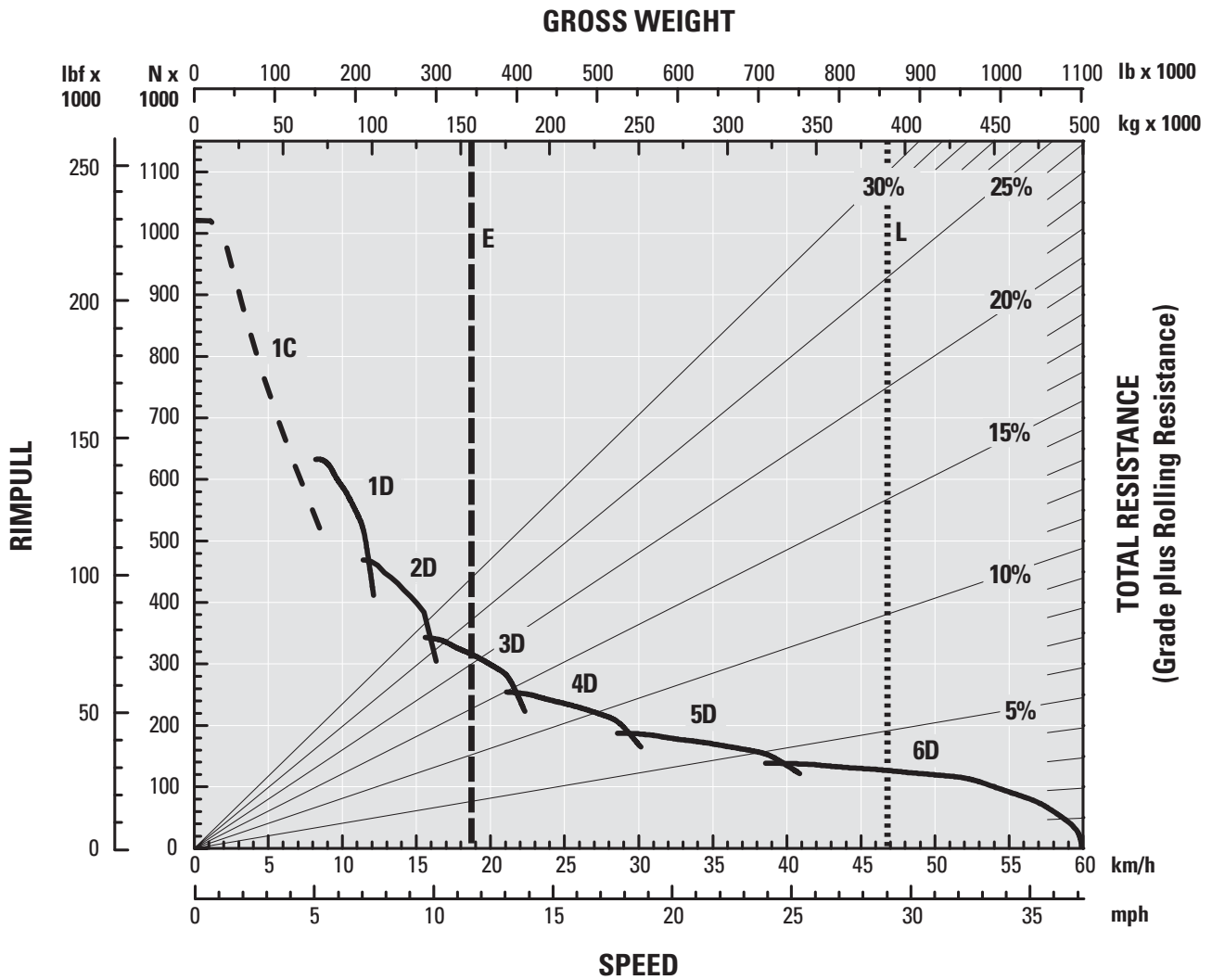

- 1 – 1st Gear
- 2 – 2nd Gear
- 3 – 3rd Gear
- 4 – 4th Gear
- 5 – 5th Gear
- 6 – 6th Gear

- E – Empty
- L – Loaded
- * at sea level

- Torque Converter Drive
- Direct Drive

793F Mining Truck Specifications

793F Standard Retarding – Continuous*

To determine retarding performance: Add lengths of all downhill segments and, using this total, refer to proper retarding chart. Read from gross weight down to the percent effective grade. Effective grade equals actual % grade minus 1% for each 10 kg/t (20 lb/ton) of rolling resistance. From this weight-effective grade point, read horizontally to the curve with the highest obtainable gear, then down to maximum descent speed brakes can properly handle without exceeding cooling capacity. The following charts are based on these conditions: 32° C (90° F) ambient temperature, at sea level, with 46/90R-57 tires.

NOTE: Select the proper gear to maintain engine rpm at the highest possible level, without overspeeding the engine. If cooling oil overheats, reduce ground speed to allow transmission to shift to the next lower speed range.

- Typical Field Empty Weight
- Gross Machine Operating Weight
390 089 kg (860,000 lb)

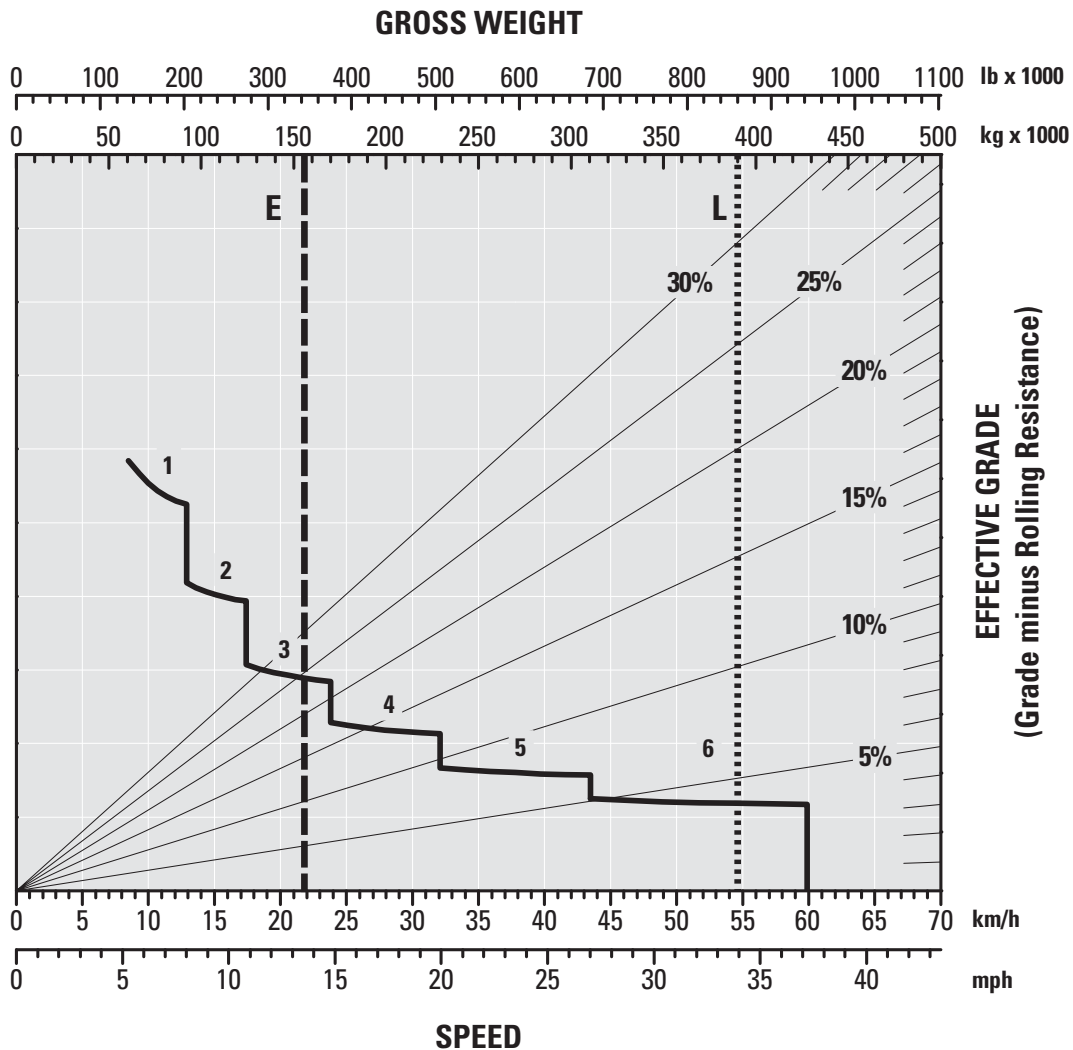

- 1 – 1st Gear
- 2 – 2nd Gear
- 3 – 3rd Gear
- 4 – 4th Gear
- 5 – 5th Gear
- 6 – 6th Gear

- E – Empty
- L – Loaded
- * at sea level

793F Standard Retarding – 450 m (1,475 ft)*

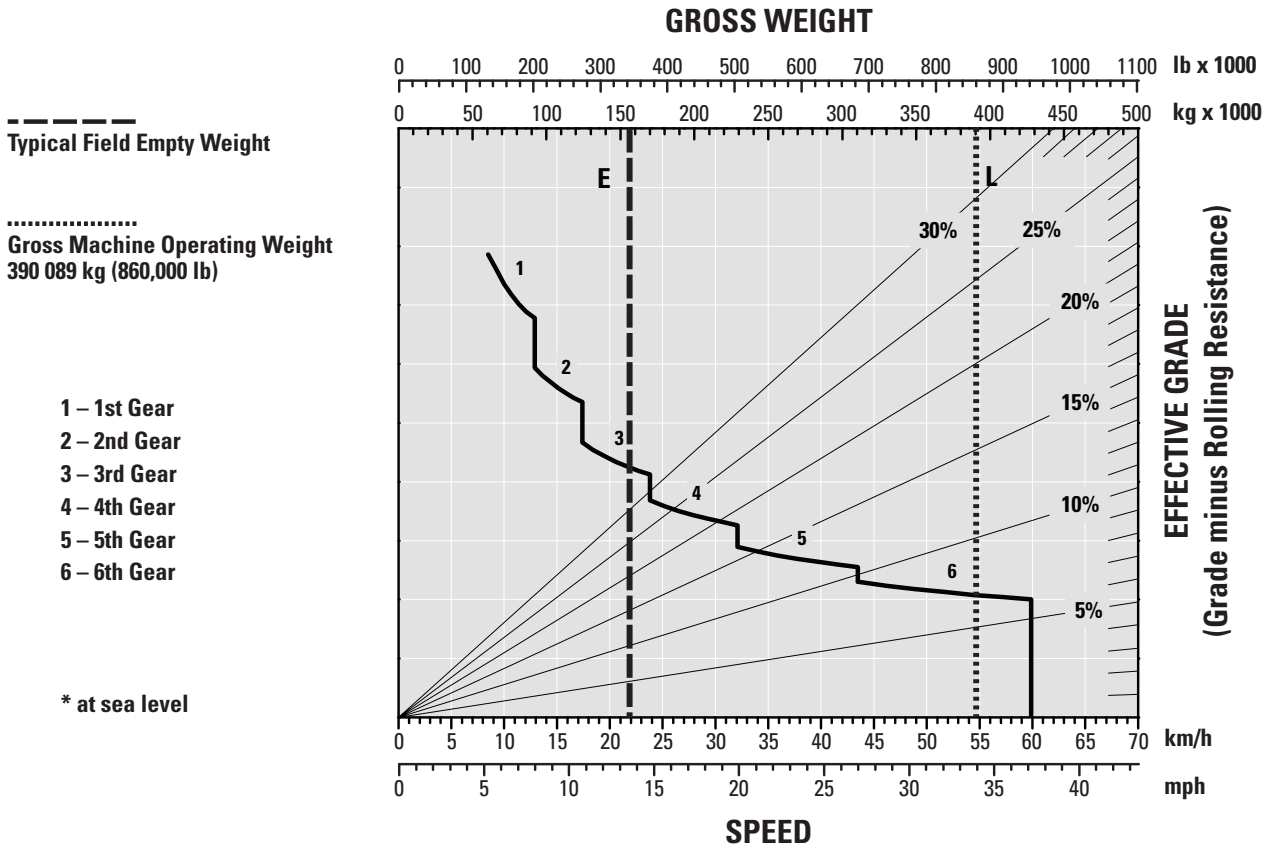

793F Standard Retarding – 1500 m (4,900 ft)*

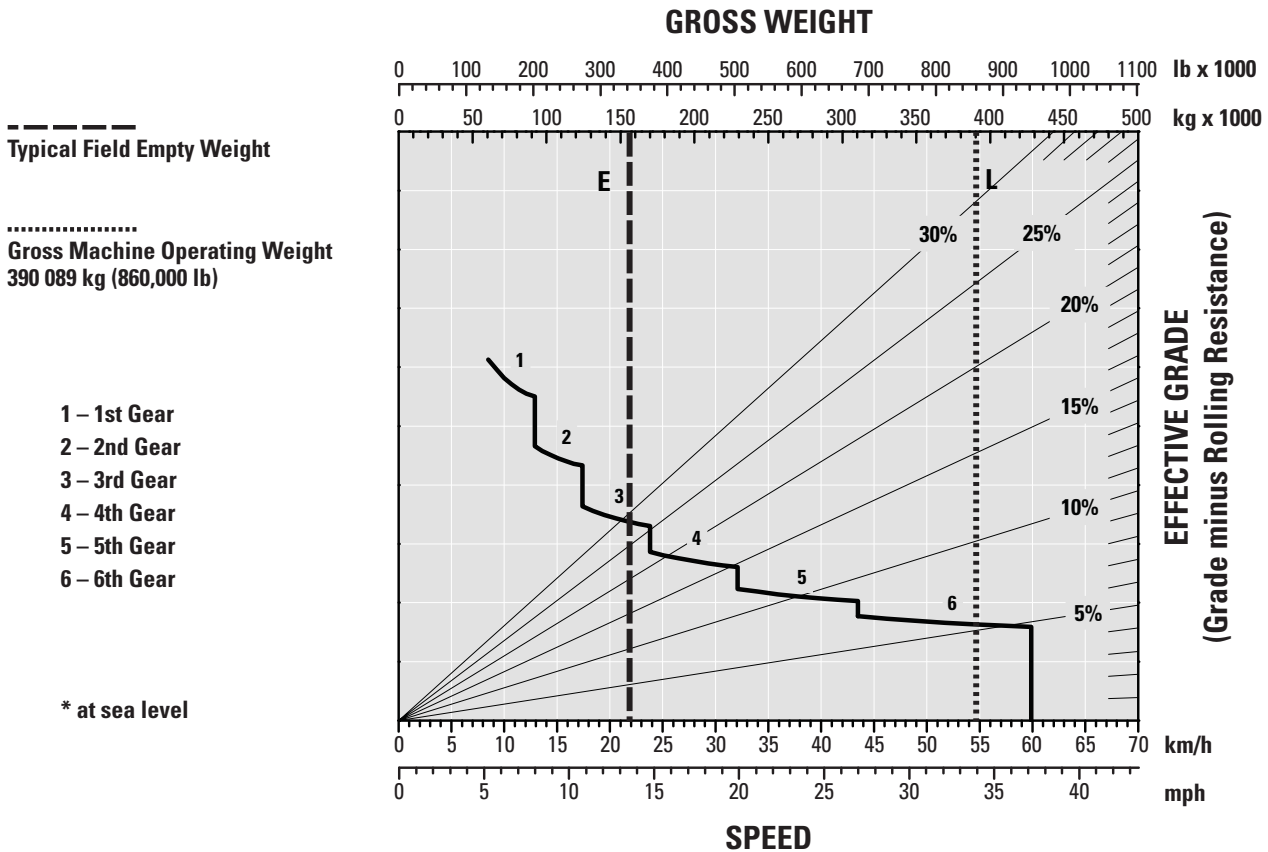

793F Mining Truck Specifications

793F Additional Retarding – Continuous*

To determine retarding performance: Add lengths of all downhill segments and, using this total, refer to proper retarding chart. Read from gross weight down to the percent effective grade. Effective grade equals actual % grade minus 1% for each 10 kg/t (20 lb/ton) of rolling resistance. From this weight-effective grade point, read horizontally to the curve with the highest obtainable gear, then down to maximum descent speed brakes can properly handle without exceeding cooling capacity. The following charts are based on these conditions: 32° C (90° F) ambient temperature, at sea level, with 46/90R-57 tires.

NOTE: Select the proper gear to maintain engine rpm at the highest possible level, without overspeeding the engine. If cooling oil overheats, reduce ground speed to allow transmission to shift to the next lower speed range.

- Typical Field Empty Weight
- Gross Machine Operating Weight
390 089 kg (860,000 lb)

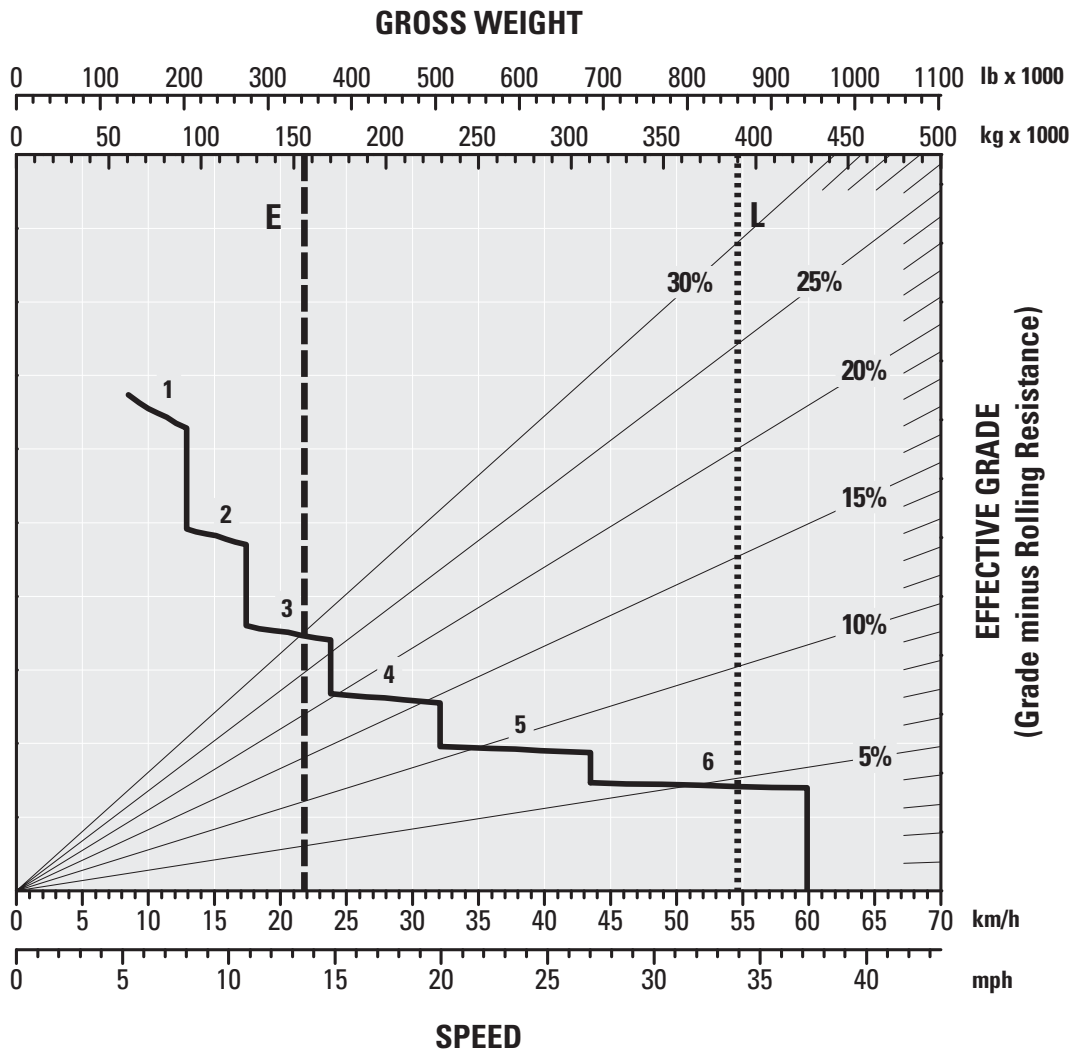

- 1 – 1st Gear
- 2 – 2nd Gear
- 3 – 3rd Gear
- 4 – 4th Gear
- 5 – 5th Gear
- 6 – 6th Gear

- E – Empty
- L – Loaded
- * at sea level

793F Additional Retarding – 450 m (1,475 ft)*

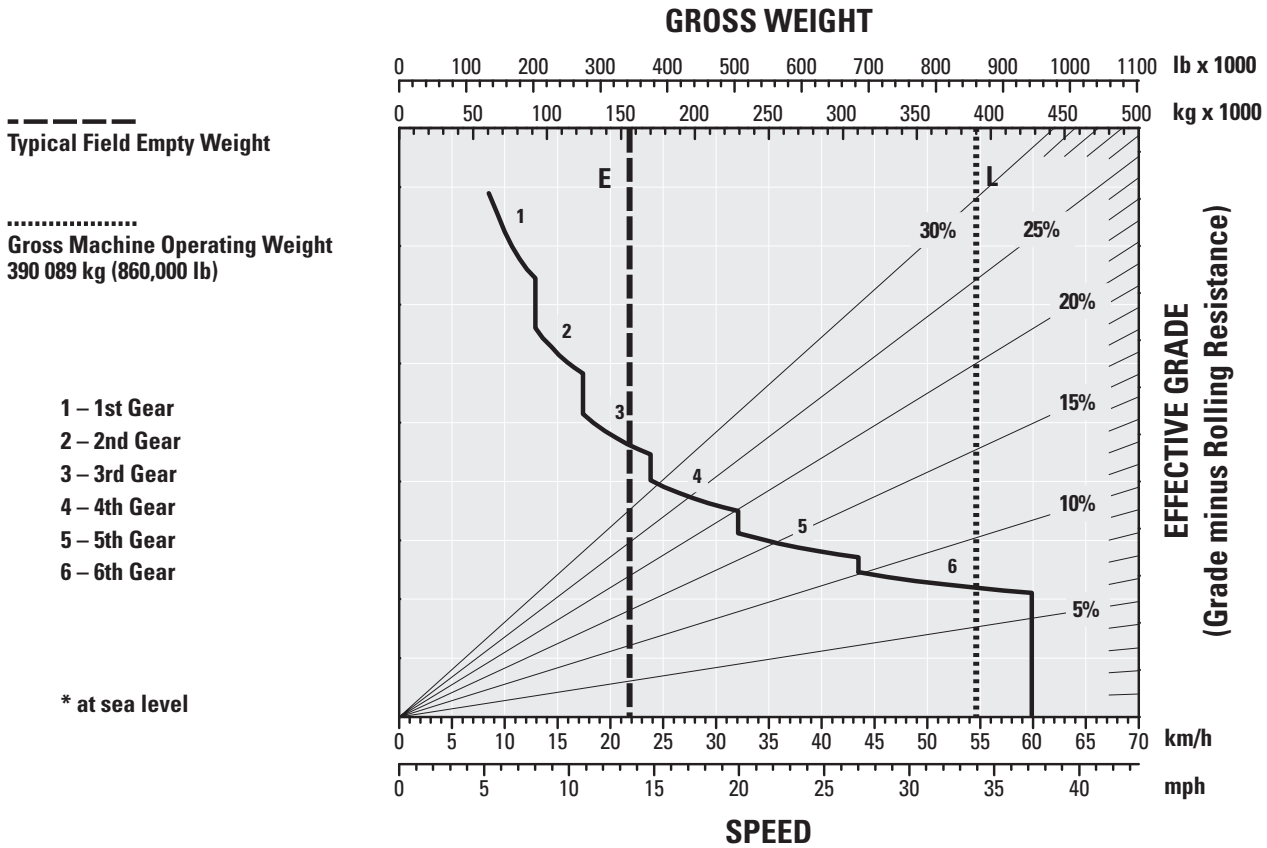

793F Additional Retarding – 1500 m (4,900 ft)*

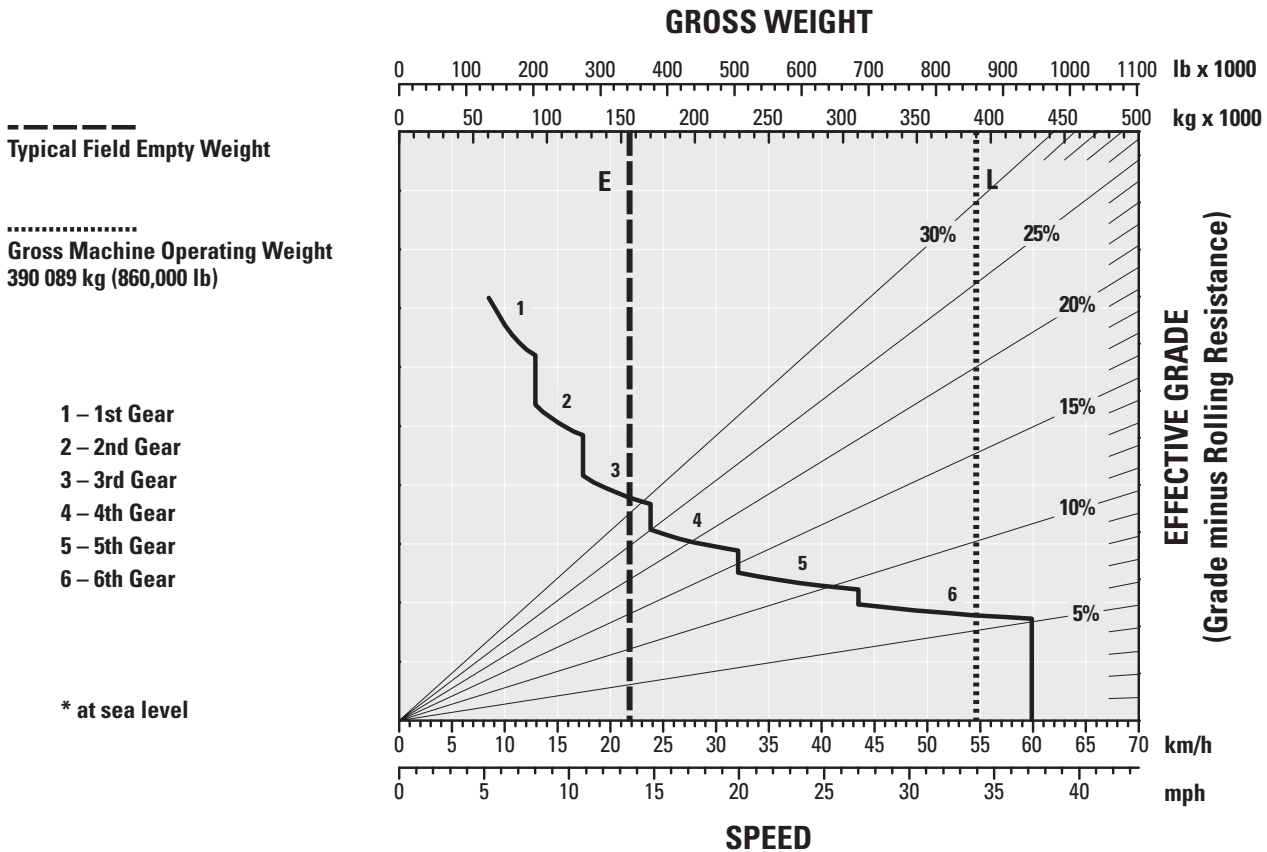

Standard Equipment

Standard equipment may vary. Consult your Cat dealer for details.

ELECTRICAL

- Alarm, Back-up
- Brushless Alternator, 150 ampere
- Batteries, 93-amp hour, low maintenance, 12-volt (2)
- Converter, 12-volt electrical
- Electrical System, 24-volt, 10, 15 and 20 amp
- Battery Charge Receptacle
- Lighting System
 - Back-up and Hazard Lights
 - Directional Signals (front and rear LED)
 - Front Stair Access/Service Deck
 - Stop/Tail Lights (LED)
 - Engine Compartment
 - VIMS, Blue Light (LED)
 - Headlights, with Lo-Hi Beam Selector

OPERATOR ENVIRONMENT

- Air Conditioner with Automatic Climate Control
- 12-volt DC Power Supply (3)
- Coat Hook
- Cup Holder
- Diagnostic Connection Port
- Dome Courtesy Light
- Entertainment Radio Ready
 - 5 amp Converter, Speakers and Wiring Harness
- Gauge/Indicators
 - Gauge Panel:
 - Transmission Fluid Temperature
 - Brake Oil Temperature
 - Engine Coolant Temperature
 - Fuel Level
 - Torque Converter Oil Temperature
 - Electric Engine Control Fault Indicator
 - Electric Hour Meter
 - Speedometer
 - Tachometer
- Heater/Defroster, 11 070 kCal (45,930 Btu)
- Hoist, Body Control (electric)
- Horn
- Integrated Object Detection System
- Mirrors, Right and Left
- ROPS Cab, Insulated/Sound Suppressed
- Seat, Operator, Air Suspension
- Seatbelt, Operator, Three Points, Retractable

- Seatbelt, Trainer, Two Points, Retractable
- Stairway and Walkway Access, 600 mm (23.6 in)
- Steering Wheel, Tilt, Padded, Telescopic
- Storage Compartments
- Tinted Glass
- Transmission Gear Indicator
- VIMS Message Center with Advisor
- Window, Operator, Electric Powered
- Windshield, Wiper Intermittent Control and Washer

POWER TRAIN

- Cat C175-16 Tier 2 Emissions Compliant Engine
 - Air Cleaner with Pre-cleaner (4)
 - Air-to-Air Aftercooler (ATAAC)
 - Automatic Starter Protection
 - Ether Starting Aid (automatic)
 - Multi-Point Oil Pressure Sensing
 - Turbocharging (4)/Aftercooled
- Braking System
 - Automatic Retarder Control, Adjustable
 - Brake Release Motor (towing)
 - Engine Overspeed Protection
 - Extended Life Brake Disc Material
 - Oil-cooled, Multi-disc (front and rear)
 - Service, Retarding, Parking, Secondary
 - Park Brake Integrated with Gear Selector
 - Secondary, Emergency
- Transmission
 - 6-speed, Automatic Powershift with Electronic Control (ECPC)
 - Body-up Reverse Neutralizer
 - Body-up Shift Inhibitor
 - Controlled Throttle Shifting
 - Directional Shift Management
 - Downshift/Reverse Shift Inhibitor
 - Individual Clutch Modulation
 - Lock-up Torque Converter
 - Neutral Coast Inhibitor
 - Neutral Start Switch
 - Programmable Top Speed
- Pre-lubrication/Engine
- Rear Axle Continuous Lubrication/Filtration

OTHER STANDARD EQUIPMENT

- Automatic Lubrication System
- Aux “Buddy” Dumping Quick Connect
- Aux Steering Quick Connect (towing)
- Driveline Guard
- Fast Fill Fuel System
- Fuel Filter with Water Separator
- Ground Level Battery Lockout
- Ground Level Engine Shut-down
- Ground Level Engine Start Lockout
- Ground Level Transmission Lockout
- Ground Level VIMS Data Port
- Hi-speed Crankcase Oil Change
- Hydraulic Filters, 1,000 hour
- Reservoirs (3 separate)
 - Brake/Hoist, Steering/Fan, Transmission/Converter
- Rock Ejectors
- Service Points, Ground Level
- Sight Level Gauges for Hydraulic/Engine Oil
- S·O·S Sample Ports
- Supplemental Steering (automatic)
- Tie Down Eyes
- Tow Hooks (front)/Tow Pin (rear)
- Traction Control System
- Vandalism Protection Locks
- Vital Information Management System (VIMS)
 - Includes VIMS Payload Monitor with MAX Payload and Speed Manager
 - Recommend using download cable 127-9797 and PC based software JERD2175. Supplemental software “VIMS Supervisor” YERA1403. Order separately. Computer not provided.

ANTIFREEZE

- Extended Life Coolant to –35° C (–30° F)

Optional Equipment

Optional equipment may vary. Consult your Cat dealer for details.

- Additional Lighting
- Additional Retarding for Downhill Hauls
- Body Heat
- Cat Comfort Air Suspension Trainer Seat
- Antifreeze/Coolant Protects to -50° C (-58° F)
- Brake Wear Indicator Gauge
- Cabin Air Precleaner
- Center Tow Bumper Attachment
- Electric Powered Window, Right Side
- Electric Starting System
- Engine Coolant and Oil Heater for Cold Weather Starts
- Engine Delay Shutdown Timer
- Extended Life Wheel Stations
- External Digital Payload Display
- External Heated Mirrors
- Fast Fill Service Center
- Fuel Tank (4920 L/1,300 gal)
- Cat Comfort Heated Operator Seat
- High Intensity Discharge (HID) Lighting (front and rear)
- Hub Odometer (km and miles)
- Portable Fire Extinguisher
- Rear Axle Lubrication Cooler
- Retractable Front Sun Visor
- Rim Guard
- Rims (813 mm/32 in)
- Road Analysis Control (RAC)
- SL-V Grease Injectors
- Throttle Lock
- Walkway and Handrail for Rear Cab Access
- Wheel Chocks
- Work Area Vision System (WAVS)

ZEPPELIN

ZEPPELIN – GANZ IN IHRER NÄHE

ZEPPELIN IN IHRER NÄHE

Mit unseren rund 40 Niederlassungen in Deutschland und Österreich sind wir immer in der Nähe Ihres Standortes oder Ihrer Baustelle. Der Zeppelin Service steht Ihnen rund um die Uhr zur Verfügung. Wir liefern 98 % aller Ersatzteile innerhalb von 24 Stunden.



ZEPPELIN DIGITAL



ZEPPELIN SHOP
KONFIGURATOR
BAGGERBÖRSE
KUNDENPORTAL



Günstige Finanzierungen
für alle unsere Maschinen
über unseren
Partner Cat Financial.

**Schnell. Einfach. Flexibel.
Individuell.**

Zeppelin Baumaschinen GmbH
Graf-Zeppelin-Platz 1 · 85748 Garching bei München
Tel. 089 32000-0 · zeppelin-cat@zeppelin.com
zeppelin-cat.de

Zeppelin Österreich GmbH
Zeppelinstraße 2 · 2401 Fischamend bei Wien
Tel. 02232 790-0 · info.at@zeppelin.com
zeppelin-cat.at

For more complete information on Cat products, dealer services,
and industry solutions, visit us on the web at www.cat.com

AEHQ6868-01 (02-2013)
Replaces AEHQ6868

© 2013 Caterpillar Inc.
All rights reserved

Materials and specifications are subject to change without notice.
Featured machines in photos may include additional equipment.
See your Cat dealer for available options.

CAT, CATERPILLAR, SAFETY.CAT.COM, their respective logos,
“Caterpillar Yellow” and the “Power Edge” trade dress, as well
as corporate and product identity used herein, are trademarks
of Caterpillar and may not be used without permission.

