



# Industrial Engine Ratings Guide

Tier 4 / Stage IIIA  
and Beyond



## Table of Contents

### Cat® Engines

Diesel Engine Rating Definitions .....	2
Rating Conditions .....	2
ISO 9001:2000 Certification .....	2
Rating Power Ranges .....	3
EPA & EU Non-Road Emissions Regulations .....	3

### Industrial Diesel Engines .....

C0.5, C0.7 .....	5
C1.1 .....	6
C1.5 .....	7
C1.6, C1.7 .....	8
C2.2 .....	9
C3.4 .....	10
C3.4B .....	11
C4.4 ACERT™ .....	12
C6.6 ACERT .....	13
C7.1 ACERT .....	14
C9.3 ACERT .....	15
C13 ACERT .....	16
C15 ACERT .....	17
C18 ACERT .....	18
C27 ACERT, C32 ACERT .....	19

### Industrial Power Units .....

C1.1 Power Unit, C1.5 Power Unit .....	21
C2.2 Power Unit .....	22
C4.4 ACERT Power Unit .....	23
C7.1 ACERT Power Unit .....	24
C9.3 ACERT Power Unit .....	25
C13 ACERT Power Unit .....	26
C15 ACERT Power Unit .....	27
C18 ACERT Power Unit .....	28

### Aftertreatment .....

C3.4B Configurations .....	30
C4.4 ACERT Configurations .....	31
C6.6 ACERT Configurations .....	32
C7.1 ACERT Configurations .....	33
C9.3 ACERT Configurations .....	34
C13 ACERT Configurations .....	35
C15 ACERT Configurations .....	36
C18 ACERT Configurations .....	37

### Technology

ACERT Technology .....	38
Electronic Control Unit (ECU) .....	38
Analog Gauge .....	38
Control and Display Panels .....	38

### Additional Literature .....

## Diesel Engine Rating Definitions

### Explanation of Ratings A, B, C, D, and E:

For an exact determination of the appropriate rating, contact your local Cat dealer. Engine rating obtained and presented in accordance with ISO3046/1.

#### IND-A (Continuous)

Continuous heavy-duty service where the engine is operated at maximum power and speed up to 100% of the time without interruption or load cycling.

#### IND-B

For service where power and/or speed are cyclic (time at full load not to exceed 80%).

#### IND-C (Intermittent)

Intermittent service where maximum power and/or speed are cyclic (time at full load not to exceed 50%).

#### IND-D

For service where maximum power is required for periodic overloads (time at full load not to exceed 10% of the duty cycle).

#### IND-E

For service where maximum power is required for a short time for initial starting or sudden overload. For emergency service where standard power is unavailable (time at full load not to exceed 5% of the duty cycle).

## Rating Conditions

### Diesel Engines — up to 7.1 liter

All rating conditions are based on ISO/TR14396, inlet air standard conditions with a total barometric pressure of 100 kPa (29.5 in Hg), with a vapor pressure of 1 kPa (.295 in Hg), and 25°C (77°F).

Performance measured using fuel to EPA specifications in 40 CFR Part 1065 and EU specifications in Directive 97/68/EC with a density of 0.845-0.850 kg/L @ 15°C (59°F) and fuel inlet temperature 40°C (104°F).

### Diesel Engines — greater than 7.1 liter

All rating conditions are based on SAE J1995, inlet air standard conditions of 99 kPa (29.31 in Hg) dry barometer and 25°C (77°F) temperature. Performance measured using a standard fuel with fuel gravity of 35° API having a lower heating value of 42,780 kJ/kg (18,390 btu/lb) when used at 29°C (84.2°F) with a density of 838.9 g/L.

## ISO 9001:2000 Certification

Factory-designed systems built at Caterpillar ISO 9001:2000 certified facilities.

## Match a Reliable Cat Engine to Your Application

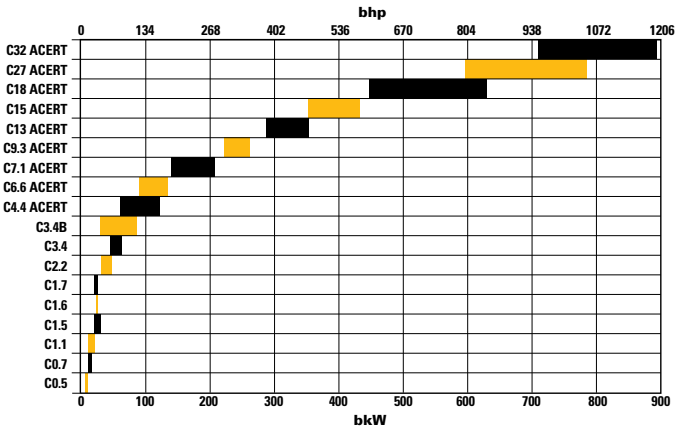

## EPA & EU Non-Road Emissions Regulations

### US EPA Nonroad

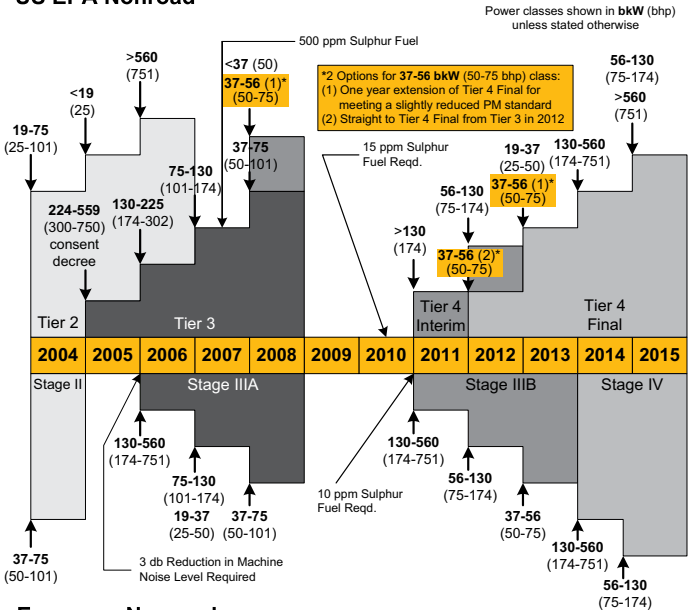

### European Nonroad

Revised 24-Mar-2010

## Customer Value

### Reliability

- Industrial engines have been validated in a wide variety of machines and applications.
- Common design across engine platforms improves reliability at first production.
- Robust electronic control systems are proven to withstand severe conditions.
- Simple, efficient turbochargers deliver reliable performance.

### Durability

- Core engine platforms deliver long life to overhaul.
- Engines are designed to be remanufactured.
- Next generation aftertreatment systems are built to withstand extreme conditions.

### Fuel Efficiency

- Improved net engine fuel consumption over Tier 3, Stage IIIA engines
- Flexible regeneration options on applicable models maximize fuel efficiency.
- Legendary Caterpillar integration expertise optimizes machine performance for maximum efficiency.

### Low-Cost of Ownership

- Value is cumulative over the entire working life of the engine.
- Precise measurement and control enables better fuel efficiency during regeneration.
- Poly-Vee belts extend service intervals.
- High resale value boosts return on investment.

### Maximum Uptime

- Ease of service
  - Oil and filter change intervals are consistent with Tier 3/Stage IIIA engines.
  - Diesel Particulate Filters (DPF) offer flexible service options where ash cleaning is required.
- Ease of operation
  - Regeneration strategies designed to keep customers working
  - Electric priming pump improves convenience
  - Single-belt accessory drive

### World-class Product Support

- Worldwide Cat dealer network, including the Cat ISD second level distributor program, helps extend engine life and reduce maintenance costs.
- Customer Service Agreements (CSA) and Extended Service Contracts (ESC) control costs and protect investment value.
- Remanufactured parts and high parts availability reduce cost and downtime.



**C0.5**

## Specifications

	<b>C0.5</b>	<b>C0.7</b>
<b>Bore x Stroke</b> . . . . .	67 x 72 mm (2.6 x 2.8 in)	67 x 72 mm (2.6 x 2.8 in)
<b>Displacement</b> . . . . .	0.5 liters (31.0 in <sup>3</sup> )	0.76 liters (46.4 in <sup>3</sup> )
<b>Ship Weight (NA)</b> . . . . .	57 kg (126 lbs)	71 kg (156.5 lbs)
<b>Approximate Dimensions:</b>		
<b>Length</b> . . . . .	407 mm (16.0 in)	480 mm (18.9 in)
<b>Width</b> . . . . .	371 mm (14.6 in)	371 mm (14.6 in)
<b>Height</b> . . . . .	523 mm (20.6 in)	528 mm (20.8 in)

### C0.5 Ratings In-Line 2

### C0.7 Ratings In-Line 3

NA	C Rating (Intermittent)		
	bkW	bhp	rpm
	8.2	11.0	2800
	8.8	11.8	3000
	10.2	13.7	3600

NA	C Rating (Intermittent)		
	bkW	bhp	rpm
	12.2	16.4	2800
	13.2	17.7	3000
	15.3	20.5	3600

## Customer Value

- Compact package
- Exceptional power density
- Extensive choice of options
- Installation flexibility

#### Abbreviations used:

NA.....Naturally Aspirated

#### Emissions Regulations for current year

Unless noted, ratings conform with EPA (U.S.) Tier 4 Interim emission standards.

**C1.1****Specifications**

	<b>C1.1</b>
<b>Bore x Stroke</b> . . . .	77 x 81 mm (3.0 x 3.2 in)
<b>Displacement</b> . . . .	1.1 liters (69 in <sup>3</sup> )
<b>Ship Weight (NA)</b>	87 kg (191 lbs)
<b>Approximate Dimensions:</b>	
<b>Length</b> . . . . .	491 mm (19.3 in)
<b>Width</b> . . . . .	400 mm (15.7 in)
<b>Height</b> . . . . .	576 mm (22.7 in)

**C1.1 Ratings In-Line 3**

		C Rating (Intermittent)		
		bkW	bhp	rpm
NA	Standard	Standard	Standard	
	14.7	19.7	2200*	
	16.1	21.6	2400*	
	17.2	23.0	2600*	
	18.5	24.8	2800*	
	19.7	26.4	3000	
	21.0	28.2	3400	
NA	Derate	Derate		
	13.7	18.4	2200	
	16.8	22.5	2800	
	17.7	23.7	3000	

**Customer Value**

- Compact package
- Exceptional power density
- Broad application range
- Low operating costs maintained
- Single-side servicing for ease of maintenance and simplified servicing routine

**Abbreviations used:**

**NA**.....Naturally Aspirated

**Emissions Regulations for current year**

Unless noted, ratings conform with EPA (U.S.) Tier 4 Interim, EU Stage IIIA emission standards.

\*Rating conforms with EPA (U.S.) Tier 4 Interim emission standards.



**C1.5**

## Specifications

	<b>C1.5</b>	<b>C1.5*</b>
<b>Bore x Stroke</b> . . . . .	84 x 90 mm (3.3 x 3.5 in)	84 x 90 mm (3.3 x 3.5 in)
<b>Displacement</b> . . . . .	1.496 liters (91 in <sup>3</sup> )	1.496 liters (91 in <sup>3</sup> )
<b>Ship Weight (NA)</b> . . . . .	149 kg (328.5 lbs) <b>(NA)</b>	156.5 kg (345 lbs) <b>(T)</b>
	156.5 kg (345 lbs) <b>(T)</b>	
<b>Approximate Dimensions:</b>		
<b>Length</b> . . . . .	572 mm (22.5 in) <b>(NA, T)</b>	572 mm (22.5 in) <b>(T)</b>
<b>Width</b> . . . . .	453 mm (17.8 in) <b>(NA)</b>	512 mm (20.2 in) <b>(T)</b>
	512 mm (20.2 in) <b>(T)</b>	
<b>Height</b> . . . . .	643 mm (25.3 in) <b>(NA, T)</b>	643 mm (25.3 in) <b>(T)</b>

## C1.5 Ratings In-Line 3

	<b>C Rating (Intermittent)</b>		
	<b>bkW</b>	<b>bhp</b>	<b>rpm</b>
<b>NA</b>			
	20.9	28.0	2200
	22.3	29.9	2400
	23.4	31.4	2600
	24.4	32.7	2800
	25.1	33.7	3000
<b>T</b>			
	23.1	31.0	2200
	25.2	33.8	2400
	27.3	36.6	2600
	29.4	39.4	2800
	30.0	40.2	3000

## C1.5 Ratings\* In-Line 3

	<b>C Rating (Intermittent)</b>		
	<b>bkW</b>	<b>bhp</b>	<b>rpm</b>
<b>T</b>			
	24.4	32.7	2800
	25.1	33.7	3000
	25.2	33.8	2400
	27	36.2	2800

## Customer Value

- Compact package
- Exceptional power density
- Broad application range
- Low operating costs maintained
- Single-side servicing for ease of maintenance and simplified servicing routine

### Abbreviations used:

**NA**.....Naturally Aspirated

**T**.....Turbocharged

### Emissions Regulations for current year

Unless noted, ratings conform with EPA (U.S.) Tier 4 Interim, EU Stage IIIA emission standards.

\*Preliminary data. Rating designed to conform with 2013 EPA (U.S.) Tier 4 Final, EU Stage IIIB emission standards.

**C1.6**

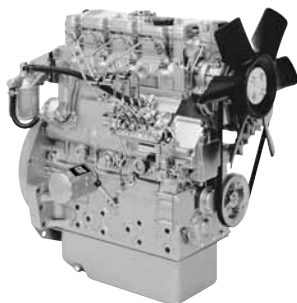

## Specifications

	<b>C1.6</b>	<b>C1.7</b>
<b>Bore x Stroke</b> . . . . .	77 x 81 mm (3.0 x 3.2 in)	84 x 100 mm (3.3 x 3.9 in)
<b>Displacement</b> . . . . .	1.5 liters (92 in <sup>3</sup> )	1.66 liters (101 in <sup>3</sup> )
<b>Ship Weight (NA)</b> . . . . .	106.8 kg (235.4 lbs)	160 kg (352.7 lbs)
<b>Approximate Dimensions:</b>		
<b>Length</b> . . . . .	591 mm (23.3 in)	564 mm (22.2 in)
<b>Width</b> . . . . .	420 mm (16.5 in)	453 mm (17.8 in)
<b>Height</b> . . . . .	576 mm (22.7 in)	654 mm (25.7 in)

### C1.6 Ratings In-Line 4

NA	C Rating (Intermittent)		
	bkW	bhp	rpm
	24.6	33.0	2800
	26.5	35.5	3000

### C1.7 Ratings In-Line 3

NA	C Rating (Intermittent)		
	bkW	bhp	rpm
	23.6	31.6	2400
	26.1	35.0	2600

## Customer Value

- Compact package
- Exceptional power density
- Broad application range
- Low operating costs maintained
- Single-side servicing for ease of maintenance and simplified servicing routine

#### Abbreviations used:

NA.....Naturally Aspirated

#### Emissions Regulations for current year

Unless noted, ratings conform with EPA (U.S.) Tier 4 Interim, EU Stage IIIA emission standards.



**C2.2**

## Specifications

	<b>C2.2</b>	<b>C2.2*</b>
<b>Bore x Stroke</b> . . . . .	84 x 100 mm (3.3 x 3.9 in)	84 x 100 mm (3.3 x 3.9 in)
<b>Displacement</b> . . . . .	2.2 liters (135 in <sup>3</sup> )	2.2 liters (135 in <sup>3</sup> )
<b>Ship Weight (NA)</b> . . . . .	184 kg (406 lbs) (NA)	184-218 kg (406-480 lbs) (NA)
	194 kg (427.7 lbs) (T, TA)	194 kg (427.7 lbs) (T)

### Approximate Dimensions:

<b>Length</b> . . . . .	661.5 mm (26 in) (NA)	661.5 mm (26.0 in) (NA)
	662 mm (26.1 in) (T, TA)	662 mm (26.1 in) (T)
<b>Width</b> . . . . .	484 mm (18.3 in) (NA)	484 mm 18.3 in) (NA)
	489 mm (19.3 in) (T, TA)	489 mm (19.3 in) (T)
<b>Height</b> . . . . .	676 mm (26.6 in) (NA)	676 mm (26.6 in) (NA)
	698 mm (27.5 in) (T, TA)	698 mm (27.5 in) (T)

## C2.2 Ratings In-Line 4

NA	C Rating (Intermittent)		rpm
	bkW Standard	bhp Standard	
	31.0	41.6	2200
	34.1	45.7	2400
	35.7	47.9	2600
	37.3	50.0	2800
	38.0	51.0	3000

NA	Derate		rpm
	Derate	Derate	
	31.4	42.1	2600
	32.8	43.9	2800
	34.0	45.6	3000

T	Standard		rpm
	Standard	Standard	
	39.8	53.3	2600
	43.0	57.7	2600
	44.7	60.0	2800
	45.5	61.0	3000

T	Derate		rpm
	Derate	Derate	
	36.3	48.7	2800

TA	Standard		rpm
	Standard	Standard	
	49.3	66.1	2800

## C2.2 Ratings\* In-Line 4

NA	C Rating (Intermittent)		rpm
	bkW	bhp	
	31.4	42.1	2600
	34.1	45.7	2400
	34.2	45.9	2600
	35.7	47.9	2600
	36.4	48.8	2800-3000

T	Standard		rpm
	Standard	Standard	
	36.4	48.8	2600-2800
	40.0	53.6	2600
	41.5	55.7	2600
	44.7	60.0	2800
	45.5	61.0	3000

## Customer Value

- Compact package
- Exceptional power density
- Broad application range
- Low operating costs maintained
- Single-side servicing for ease of maintenance and simplified servicing routine

### Abbreviations used:

NA.....Naturally Aspirated

TA.....Turbocharged-Aftercooled

T.....Turbocharged

### Emissions Regulations for current year

Unless noted, ratings conform with EPA (U.S.) Tier 4 Interim, EU Stage IIIA emission standards.

\*Preliminary data. Rating designed to conform with 2013 EPA (U.S.) Tier 4 Final, EU Stage IIIB emission standards.

**C3.4**

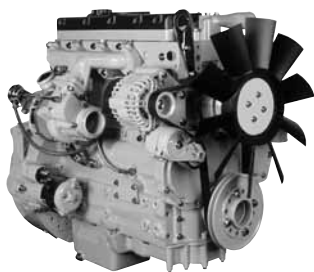

## Specifications

	<b>C3.4</b>
<b>Bore x Stroke . . . .</b>	94 x 120 mm (3.7 x 4.72 in)
<b>Displacement . . . .</b>	3.3 liters (201 in <sup>3</sup> )
<b>Ship Weight (NA).</b>	245 kg (540 lbs) (NA)
	265 kg (584 lbs) (T)
<b>Approximate Dimensions:</b>	
<b>Length . . . . .</b>	781 mm (30.7 in) (NA)
	784 mm (30.9 in) (T)
<b>Width . . . . .</b>	590 mm (23.2 in) <b>High Turbo</b>
	649 mm (25.5 in) <b>Low Turbo</b>
<b>Height . . . . .</b>	722 mm (28.4 in) (NA)
	821.3 mm (32.3 in) (T)

## C3.4 Ratings In-Line 4

	C Rating (Intermittent)		
	bkW	bhp	rpm
<b>NA</b>			
	47	63	2500
<b>T</b>			
	55	73.7	2500
	62	83	2500*

## Customer Value

- Compact package
- Exceptional power density
- Broad application range
- Low operating costs maintained
- Single-side servicing for ease of maintenance and simplified servicing routine

### Abbreviations used:

**NA**.....Naturally Aspirated

**TA**.....Turbocharged-Aftercooled

**T**.....Turbocharged

### Emissions Regulations for current year

Unless noted, ratings conform with EPA (U.S.) Tier 4 Interim, EU Stage IIIA emission standards.

\*Rating conforms with EPA (U.S.) Tier 3, EU Stage IIIA emission standards.

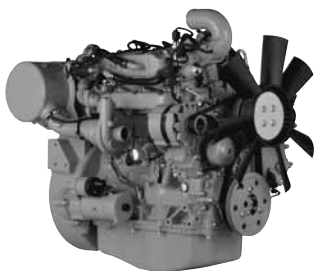

**C3.4B**

## Specifications

	<b>C3.4B</b>
<b>Bore x Stroke</b> . . . .	99 x 110 mm (3.9 x 4.3 in)
<b>Displacement</b> . . . .	3.4 liters (207.5 in <sup>3</sup> )
<b>Ship Weight</b> . . . . .	275 kg (606.3 lbs) (T)
	270 kg (595.2 lbs) (TA)

### Approximate Dimensions:

	<b>Top Turbo</b>	<b>Side Turbo</b>
<b>Length</b> . . . . .	871 mm (34.3 in)	940 mm (37.0 in)
<b>Width</b> . . . . .	653 mm (25.7 in)	662 mm (26.0 in)
<b>Height</b> . . . . .	829 mm (32.6 in)	805 mm (31.7 in)

## C3.4B Ratings\* In-Line 4

	C Rating (Intermittent)		
	b kW	b hp	rpm
<b>T</b>			
	45.0	60.3	2200**
	47.0	63.0	2500**
	50.0	67.0	2200**
	55.4	74.3	2200 & 2500**
<b>TA (ATAAC)</b>			
	63.0	84.5	2200
	66.0	88.5	2200 & 2500
	70.5	94.5	2200
	75.0	100.6	2200 & 2500
	83.0	111.3	2200
	86.0	115.3	2500

## Customer Value

- Compact package
- Extensive choice of options
- Installation flexibility
- Twin PTO capability
- Engine or machine mounted aftertreatment
- Service-free top end for reduced maintenance
- Poly-Vee belts for longer service intervals

### Abbreviations used:

- T.....Turbocharged
- TA.....Turbocharged-Aftercooled
- ATAAC.....Air-to-Air Aftercooled

Unless noted, ratings designed to conform with 2012 EPA (U.S.) Tier 4 Interim, EU Stage IIIB emission standards

\*Preliminary Data

\*\*Rating designed to conform with 2013 EPA (U.S.) Tier 4 Final, EU Stage IIIB emission standards.

## C4.4 ACERT

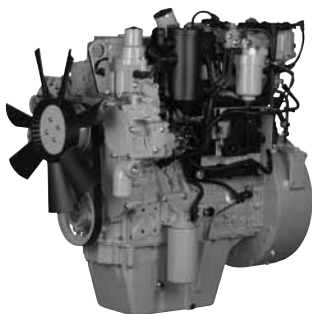

### Specifications

#### C4.4 ACERT

<b>Bore x Stroke</b> . . . .	105 x 127 mm (4.1 x 5.0 in)
<b>Displacement</b> . . . .	4.4 liters (268.5 in <sup>3</sup> )
<b>Ship Weight</b> . . . . .	400-450 kg (881.8-992.0 lbs)

#### Approximate Dimensions:

<b>Length</b> . . . . .	845.1 mm (33.3 in) (TA, TTA)
<b>Width</b> . . . . .	772.4 mm (30.4 in) (TA) 741.6 mm (29.1 in) (TTA)
<b>Height</b> . . . . .	848.2 mm (33.4 in) (TA) 867.6 mm (34.1 in) (TTA)

### C4.4 ACERT Ratings In-Line 4

B Rating			C Rating (Intermittent)		
bkW	bhp	rpm	bkW	bhp	rpm
<b>TA (ATAAC)</b>					
65.9	88.4	2200	61.5	82.5	2200
70.0	93.9	2200	74.5	99.9	2200
85.9	115.2	2200	82.0	110.0	2200
91.0	122.0	2200	98.0	131.4	2200
92.5	124.0	2200	102.1	137.0	2200
112.0	150.0	2200	106.0	142.1	2200
—	—	—	110.1	147.6	2200
<b>TTA (ATAAC)</b>					
105.1	141.0	2200	117.0	157.0	2200
—	—	—	129.4	173.5	2200

### Customer Value

- Increased power and torque over Tier 3/Stage IIIA engine
- Compact package
- Extensive choice of options
- Installation flexibility
- Non-modular aftertreatment
- Maintenance-free valve adjustment
- Poly-Vee belts for longer service intervals
- Two-stage turbocharger with smart wastegate available on some ratings for increased performance

#### Abbreviations used:

**TA**.....Turbocharged-Aftercooled

**ATAAC**.....Air-to-Air Aftercooled

Unless noted, ratings designed to conform with 2012 EPA (U.S.) Tier 4 Interim, EU Stage IIIB emission standards.

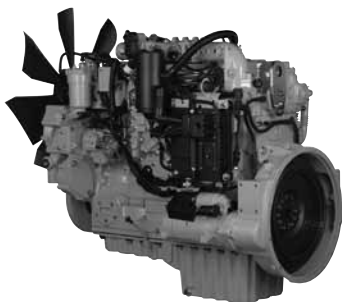

**C6.6 ACERT**

## Specifications

<b>C6.6 ACERT</b>	
<b>Bore x Stroke</b> . . . .	105 x 127 mm (4.1 x 5.0 in)
<b>Displacement</b> . . . .	6.6 liters (402.8 in <sup>3</sup> )
<b>Ship Weight (TA)</b> .	695 kg (1532 lbs)
<b>Approximate Dimensions:</b>	
<b>Length</b> . . . . .	1063.7 mm (41.9 in)
<b>Width</b> . . . . .	753 mm (29.6 in)
<b>Height</b> . . . . .	907 mm (35.7 in)

## C6.6 ACERT Ratings In-Line 6

	<b>C Rating</b> (Intermittent)		
	<b>bkW</b>	<b>bhp</b>	<b>rpm</b>
<b>TA (ATAAC)</b>			
	89.0	119.3	2200
	116.5	156.2	2200
	129.4	173.5	2200

## Customer Value

- Compact package
- Extensive choice of options
- Installation flexibility
- Non-modular aftertreatment
- Maintenance-free valve adjustment
- Poly-Vee belts for longer service intervals
- Common rail fuel system
- Similar connection points to Tier 3/Stage IIIA engine

### Abbreviations used:

**TA**.....Turbocharged-Aftercooled

**ATAAC**.....Air-to-Air Aftercooled

Unless noted, ratings designed to conform with 2012 EPA (U.S.) Tier 4 Interim, EU Stage IIIB emission standards.

## C7.1 ACERT

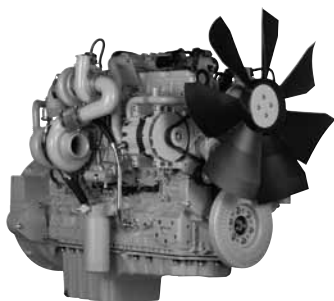

### Specifications

	<b>C7.1 ACERT</b>
<b>Bore x Stroke</b> . . . .	105 x 135 mm (4.1 x 5.3 in)
<b>Displacement</b> . . . .	7.0 liters (427.7 in <sup>3</sup> )
<b>Ship Weight</b> . . . . .	715 kg (1576 lbs)
<b>Approximate Dimensions:</b>	
<b>Length</b> . . . . .	1063.7 mm (41.9 in)
<b>Width</b> . . . . .	820.2 mm (32.3 in)
<b>Height</b> . . . . .	907 mm (35.7 in)

### C7.1 ACERT Ratings In-Line 6

B Rating			C Rating (Intermittent)			D Rating		
bkW	bhp	rpm	bkW	bhp	rpm	bkW	bhp	rpm
<b>TA (ATAAC)</b>								
140.0	187.7	2200	186.5	250.1	2200	225.0	301.7	2200
151.0	202.5	2200	205.0	274.9	2200	—	—	—
158.5	212.5	2200	—	—	—	—	—	—
168.0	225.3	2200	—	—	—	—	—	—
176.5	236.7	2200	—	—	—	—	—	—

### Customer Value

- Compact package
- Extensive choice of options
- Modular aftertreatment
- Maintenance-free valve adjustment
- Poly-Vee belts for longer service intervals
- Series turbochargers with smart wastegate available on all ratings for increased performance
- Common rail fuel system
- Similar connection points to Tier 3/Stage IIIA engine

#### Abbreviations used:

**TA**.....Turbocharged-Aftercooled

**ATAAC**.....Air-to-Air Aftercooled

#### Emissions Regulations for current year

Unless noted, ratings conform with EPA (U.S.) Tier 4 Interim, EU Stage IIIB emission standards.

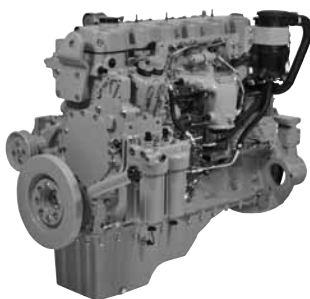

**C9.3 ACERT**

## Specifications

<b>C9.3 ACERT</b>	
<b>Bore x Stroke</b> . . . .	115 x 149 mm (4.53 x 5.87 in)
<b>Displacement</b> . . . .	9.3 liters (567.5 in <sup>3</sup> )
<b>Ship Weight</b> . . . . .	885 kg (1950 lbs)
<b>Approximate Dimensions:</b>	
<b>Length</b> . . . . .	1150 mm (45.3 in)
<b>Width</b> . . . . .	827 mm (32.6 in)
<b>Height</b> . . . . .	1123 mm (44.2 in)

## C9.3 ACERT Ratings In-Line 6

<b>A Rating</b> (Continuous)			<b>B Rating</b>			<b>C Rating</b> (Intermittent)		
<b>bkW</b>	<b>bhp</b>	<b>rpm</b>	<b>bkW</b>	<b>bhp</b>	<b>rpm</b>	<b>bkW</b>	<b>bhp</b>	<b>rpm</b>
<b>TA (ATAAC)</b>								
224	300	1800-	242	325	1800-	261	350	1800-
		2200			2200			2200

## Customer Value

- Engine size similar to Tier 3, Stage IIIA engine
- Increased displacement — 9.3 L
- Increased power density
- Similar connection points to Tier 3, Stage IIIA engine
- Electric priming pump for faster, easier priming
- Enhanced electronic features
- Common Rail fuel system
- Simple, efficient turbocharger for increased performance

### Abbreviations used:

**TA**.....Turbocharged-Aftercooled

**ATAAC**.....Air-to-Air Aftercooled

### Emissions Regulations for current year

Unless noted, ratings conform with EPA (U.S.) Tier 4 Interim, EU Stage IIIB emission standards.

## C13 ACERT



### Specifications

	<b>C13 ACERT</b>
<b>Bore x Stroke</b>	130 x 157 mm (5.1 x 6.2 in)
<b>Displacement</b> . . . . .	12.5 liters (762.8 in <sup>3</sup> )
<b>Ship Weight</b> . . . . .	1350 kg (2976 lbs)
<b>Approximate Dimensions:</b>	
<b>Length</b> . . . . .	1203 mm (47.2 in)
<b>Width</b> . . . . .	933.1 mm (36.7 in)
<b>Height</b> . . . . .	1186 mm (46.7 in)

### C13 ACERT Ratings In-Line 6

A Rating (Continuous)			B Rating			C Rating (Intermittent)			D Rating			E Rating		
bkW	bhp	rpm	bkW	bhp	rpm	bkW	bhp	rpm	bkW	bhp	rpm	bkW	bhp	rpm
<b>TA (ATAAC)</b>														
287	385	1800-	309	415	1800-	328	440	1800-	354	475	1800-	388	520	1800-
		2100			2100			2100			2100			2100

### Customer Value

- Engine size similar to Tier 3, Stage IIIA engine
- Similar connection points to Tier 3, Stage IIIA engine
- Electric priming pump for faster, easier priming
- Enhanced electronic features
- Improved MEUI-C fuel system
- Simple, efficient turbocharger for increased performance

#### Abbreviations used:

TA.....Turbocharged-Aftercooled

ATAAC.....Air-to-Air Aftercooled

#### Emissions Regulations for current year

Unless noted, ratings conform with EPA (U.S.) Tier 4 Interim, EU Stage IIIB emission standards.

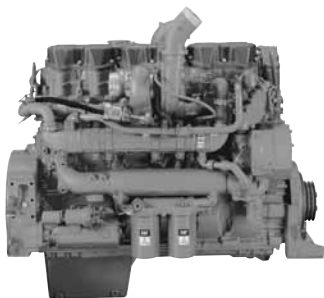

**C15 ACERT**

## Specifications

	<b>C15 ACERT</b>
<b>Bore x Stroke</b>	137 x 171 mm (5.4 x 6.73 in)
<b>Displacement</b> . . . . .	15.2 liters (927.6 in <sup>3</sup> )
<b>Ship Weight</b> . . . . .	1666 kg (3673 lbs)
<b>Approximate Dimensions:</b>	
<b>Length</b> . . . . .	1438 mm (56.6 in)
<b>Width</b> . . . . .	943 mm (37.1 in)
<b>Height</b> . . . . .	1239 mm (48.8 in)

## C15 ACERT Ratings In-Line 6

<b>A Rating*</b> (Continuous)	<b>B Rating</b>	<b>C Rating</b> (Intermittent)	<b>D Rating</b>
bkW bhp rpm	bkW bhp rpm	bkW bhp rpm	bkW bhp rpm
<b>TA (ATAAC)</b>			
354 475 1800- 2100	354 475 1800- 2100	403 540 1800- 2100	433 580 1800- 2100

\*Altitude-limited

## Customer Value

- Engine size similar to Tier 3, Stage IIIA engine
- Similar connection points to Tier 3, Stage IIIA engine
- Electric priming pump for faster, easier priming
- Enhanced electronic features
- Improved MEUI-C fuel system
- Simple, efficient turbocharger for increased performance

### Abbreviations used:

**TA**.....Turbocharged-Aftercooled

**ATAAC**.....Air-to-Air Aftercooled

### Emissions Regulations for current year

Unless noted, ratings conform with EPA (U.S.) Tier 4 Interim, EU Stage IIIB emission standards.

## C18 ACERT

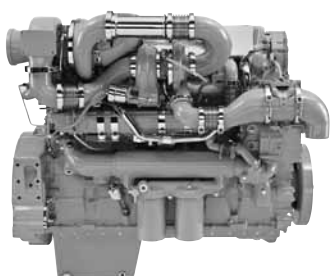

### Specifications

	<b>C18 ACERT</b>	
<b>Bore x Stroke</b>	145 x 183 mm (5.71 x 7.2 in)	
<b>Displacement</b> . . . . .	18.1 liters (1104.5 in <sup>3</sup> )	
<b>Ship Weight</b>	1666 kg (3673 lbs) (≤ 522 bkW/700 bhp) 1717 kg (3785 lbs) (> 522 bkW/700 bhp)	
	<b>C18 ACERT</b>	
	<b>&lt; 522 bkW (700 bhp)</b>	<b>&gt; 522 bkW (700 bhp)</b>
<b>Approximate Dimensions:</b>		
<b>Length</b> . . . . .	1438 mm (56.6 in)	1438 mm (56.6 in)
<b>Width</b> . . . . .	943 mm (37.1 in)	1024 mm (40.3 in)
<b>Height</b> . . . . .	1239 mm (48.8 in)	1356 mm (53.4 in)
	<b>563-597 bkW (755-800 bhp)</b>	
<b>Approximate Dimensions:</b>		
<b>Length</b> . . . . .	1438 mm (56.6 in)	
<b>Width</b> . . . . .	1132 mm (44.6 in)	
<b>Height</b> . . . . .	1356 mm (53.4 in)	

### C18 ACERT Ratings In-Line 6

A Rating* (Continuous)	B Rating			C Rating (Intermittent)			D Rating					
	bkW	bhp	rpm	bkW	bhp	rpm	bkW	bhp	rpm			
TA (ATAAC)	447	600	1800-1900	447	600	1800-1900	470	630	1800-1900	—	—	—
TTA (ATAAC)	—	—	—	—	—	—	522	700	1800-1900	597	800	1800-1900**
	—	—	—	—	—	—	563	755	1800-1900**	—	—	—

\*Altitude-limited

### Customer Value

- Engine size similar to Tier 3, Stage IIIA engine
- Similar connection points to Tier 3, Stage IIIA engine
- Electric priming pump for faster, easier priming
- Enhanced electronic features
- Improved MEUI-C fuel system
- Simple, efficient turbocharger (<522 kW, 700 hp) and series turbocharger (≥ 522 kW, 700 hp) for increased performance

#### Abbreviations used:

TA.....Turbocharged-Aftercooled

ATAAC.....Air-to-Air Aftercooled

#### Emissions Regulations for current year

Unless noted, ratings conform with EPA (U.S.) Tier 4 Interim, EU Stage IIIB emission standards.

\*\*Rating conforms with EPA (U.S.) Tier 4 Interim (563 bkW/755 bhp @ 1800-1900 rpm) and Tier 4 Final emission standards (563 bkW/755 bhp @1800 rpm, 597 bkW/800 bhp @ 1800 rpm).



**C27 ACERT**

## Specifications

	<b>C27 ACERT</b>	<b>C32 ACERT</b>
<b>Bore x Stroke</b> . . . . .	137.2 x 152.4 mm (5.4 x 6.0 in)	145.0 x 162 mm (5.71 x 6.38 in)
<b>Displacement</b> . . . . .	27 liters (1649.5 in <sup>3</sup> )	32.1 liters (1959 in <sup>3</sup> )
<b>Ship Weight</b> . . . . .	3004 kg (6625 lbs)	3004 kg (6625 lbs)
<b>Approximate Dimensions:</b>		
<b>Length</b> . . . . .	1874 mm (73.8 in)	1874 mm (73.8 in)
<b>Width</b> . . . . .	1600 mm (63.0 in)	1600 mm (63.0 in)
<b>Height</b> . . . . .	1370 mm (53.9 in)	1370 mm (53.9 in)

## C27 ACERT Ratings V-12

<b>A Rating</b> (Continuous)			<b>B Rating</b>			<b>C Rating</b> (Intermittent)			<b>D Rating</b>		
bkW	bhp	rpm	bkW	bhp	rpm	bkW	bhp	rpm	bkW	bhp	rpm
<b>TA (ATAAC)</b>											
597	800	1800-2100	653	875	1800-2100	709	950	1800-2100	783	1050	1800-2100

## C32 ACERT Ratings V-12

<b>B Rating</b>			<b>C Rating</b>			<b>D Rating</b> (Intermittent)		
bkW	bhp	rpm	bkW	bhp	rpm	bkW	bhp	rpm
<b>TA (ATAAC)</b>								
709	950	1800-2100	839	1125	1800-2100	895	1200	1800-2100

## Customer Value

- Engine size similar to Tier 2 engine
- Similar connection points to Tier 2 engine
- Electric priming pump for faster, easier priming
- Enhanced electronic features
- Improved MEUI-C fuel system
- Simple, efficient side-mounted turbochargers for increased performance

### Abbreviations used:

**TA**.....Turbocharged-Aftercooled

**ATAAC**.....Air-to-Air Aftercooled

### Emissions Regulations for current year

Unless noted, ratings conform with EPA (U.S.) Tier 4 Interim emission standards.

## Customer Value

### Flexibility

- Complete factory-installed power unit — plug and play
- Mandatory and optional attachments can include: radiator, air cleaner, alternator, A/C compressor, air compressor, muffler, clutch, control panel, engine base, CEM, CEM support structure.
- Flexible configurations
- Minimum or no engineering work for equipment manufacturers

### Reliability

- Common design across engine platforms improves reliability at first production.
- Robust electronic control systems are proven to withstand severe conditions.
- Simple, efficient turbochargers deliver reliable performance.

### Durability

- Core engine platforms deliver long life to overhaul.
- Engines are designed to be remanufactured.
- Next generation aftertreatment systems are built to withstand extreme conditions.

### Fuel Efficiency

- Improved net engine fuel consumption
- Flexible regeneration options on applicable models maximize fuel efficiency.
- Legendary Caterpillar integration expertise optimizes machine performance for maximum efficiency.

### Low-Cost of Ownership

- Value is cumulative over the entire working life of the power unit.
- Precise measurement and control enables better fuel efficiency during regeneration.
- High resale value boosts return on investment.

### Maximum Uptime

- Ease of service
- Ease of operation

### World-class Product Support

- Worldwide Cat dealer network, including the Cat ISD second level distributor program, helps extend power unit life and reduce maintenance costs.
- Customer Service Agreements (CSA) and Extended Service Contracts (ESC) control costs and protect investment value.
- Remanufactured parts and high parts availability reduce cost and downtime.



**C1.1**

## Specifications

	C1.1 Power Unit	C1.5 Power Unit
<b>Bore x Stroke</b> . . . . .	77 x 81 mm (3.0 x 3.2 in)	84 x 90 mm (3.3 x 3.5 in)
<b>Displacement</b> . . . . .	1.1 liters (69 in <sup>3</sup> )	1.496 liters (91 in <sup>3</sup> )
<b>Ship Weight (NA)</b> . . . . .	129 kg (284 lbs)	175 kg (385.8 lbs)
<b>Approximate Dimensions:</b>		
<b>Length</b> . . . . .	778 mm (30.6 in)	820 mm (32.3 in)
<b>Width</b> . . . . .	438 mm (17.2 in)	497 mm (19.6 in)
<b>Height</b> . . . . .	730 mm (28.7 in)	793 mm (31.2 in)

## C1.1 Power Unit Ratings

In-Line 3

NA	C Rating (Intermittent)		
	bkW	bhp	rpm
	17.3	23.2	2800
	18.1	24.3	3000

## C1.5 Power Unit Ratings

In-Line 3

NA	C Rating (Intermittent)		
	bkW	bhp	rpm
	24.2	32.5	3000

## Customer Value

- Compact package
- Exceptional power density
- Broad application range
- Low operating costs maintained
- Single-side servicing for ease of maintenance and simplified servicing routine

### Abbreviations used:

NA.....Naturally Aspirated

**EPA Compliant for current year**

Unless noted, ratings conform with EPA (U.S.) Tier 4 Interim, EU Stage IIIA emission standards.

**C2.2**



## Specifications

<b>C2.2 Power Unit</b>	
<b>Bore x Stroke . . .</b>	84 x 100 mm (3.3 x 3.9 in)
<b>Displacement . . .</b>	2.2 liters (135 in <sup>3</sup> )
<b>Ship Weight (NA).</b>	218 kg (480 lbs) (NA)
	228 kg (502 lbs) (T)
<b>Approximate Dimensions:</b>	
<b>Length . . . . .</b>	946 mm (37.2 in) (NA)
	973 mm (38.3 in) (T)
<b>Width . . . . .</b>	513 mm (20.2 in) (NA)
	590 mm (23.2 in) (T)
<b>Height . . . . .</b>	854 mm (33.6 in) (NA)
	973 mm (38.3 in) (T)

## C2.2 Power Unit Ratings In-Line 4

<b>C Rating</b> (Intermittent)			
<b>NA</b>	<b>bkW</b>	<b>bhp</b>	<b>rpm</b>
	37	49.6	3000
<b>T</b>			
	41.7	55.9	2800

## Customer Value

- Compact package
- Exceptional power density
- Broad application range
- Low operating costs maintained
- Single-side servicing for ease of maintenance and simplified servicing routine

### Abbreviations used:

**NA**.....Naturally Aspirated

**T**.....Turbocharged

**EPA Compliant for current year**

Unless noted, ratings conform with EPA (U.S.) Tier 4 Interim, EU Stage IIIA emission standards.



**C4.4 ACERT**

## Specifications

<b>C4.4 ACERT</b>	
<b>Bore x Stroke . . . .</b>	105 x 127 mm (4.1 x 5.0 in)
<b>Displacement . . . .</b>	4.4 liters (268.5 in <sup>3</sup> )
<b>Ship Weight . . . . .</b>	650 kg (1433 lbs) (TA) 700 kg (1543 lbs) (TTA)
<b>Approximate Dimensions:</b>	
<b>Length . . . . .</b>	1433 mm (56.4 in) (TA, TTA)
<b>Width . . . . .</b>	820 mm (32.3 in) (TA) 795 mm (31.3 in) (TTA)
<b>Height . . . . .</b>	1126 mm (44.3 in) < 82 bkW (110 bhp) (TA) 1150 mm (45.3 in) < 82 bkW (110 bhp) (TA) 1150 mm (45.3 in) (TTA)

## C4.4 ACERT Power Unit Ratings\* In-Line 4

	B Rating			C Rating (Intermittent)		
	bkW	bhp	rpm	bkW	bhp	rpm
<b>TA (ATAAC)</b>						
	—	—	—	74.5	100	2200
	—	—	—	82	110	2200
	92.5	124	2200	102.1	137	2200
	—	—	—	110	148	2200
<b>TTA (ATAAC)</b>						
	—	—	—	117	157	2200
	—	—	—	129.4	173.5	2200

## Customer Value

- Engine-mounted DPF
- Hydraulic tappet adjustment
- Can be factory-installed with or without DPF
- Sound improvement over Tier 3/Stage IIIA power unit
- Increased power
- Single turbocharger and series turbocharger options
- Service-free DPF

### Abbreviations used:

- TA.....Turbocharged-Aftercooled
- TTA.....Twin Turbocharged-Aftercooled
- ATAAC.....Air-to-Air Aftercooled

Unless noted, ratings designed to conform with 2012 EPA (U.S.) Tier 4 Interim, EU Stage IIIB emission standards.

\*Preliminary Data

## C7.1 ACERT

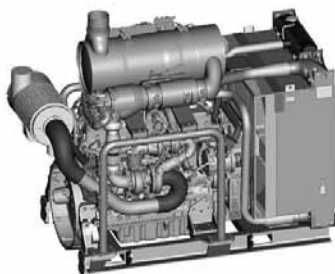

### Specifications

	<b>C7.1 ACERT Power Unit</b>
<b>Bore x Stroke</b>	105 x 135 mm (4.13 x 5.3 in)
<b>Displacement</b> . . . . .	7.0 liters (427.7 in <sup>3</sup> )
<b>Ship Weight</b> . . . . .	1200 kg (2645.5 lbs)
<b>Approximate Dimensions:</b>	
<b>Length</b> . . . . .	1750 mm (68.9 in)
<b>Width</b> . . . . .	900 mm (35.4 in)
<b>Height</b> . . . . .	1214 mm (47.8 in)

### C7.1 ACERT Power Unit Ratings In-Line 6

	B Rating			C Rating (Intermittent)		
	bkW	bhp	rpm	bkW	bhp	rpm
<b>TA (ATAAC)</b>						
	151	202	1800-2200	186	250	1800-2200
	168	225	1800-2200	205	275	1800-2200

### Customer Value

- Base CEM mounted above engine
- Hydraulic tappet adjustment
- Can be factory-installed with or without base CEM
- Sound improvement over Tier 3/Stage IIIA power unit
- Improved mounting points
- Series turbocharger with smart wastegate

#### Abbreviations used:

TA.....Turbocharged-Aftercooled

ATAAC.....Air-to-Air Aftercooled

#### Emissions Regulations for current year

Unless noted, ratings conform with EPA (U.S.) Tier 4 Interim, EU Stage IIIB emission standards.



**C9.3 ACERT**

## Specifications

<b>C9.3 ACERT Power Unit</b>	
<b>Bore x Stroke</b>	115 x 149 mm (4.53 x 5.87 in)
<b>Displacement</b> . . . . .	9.3 liters (567.5 in <sup>3</sup> )
<b>Ship Weight</b> . . . . .	1839 kg (4055 lbs)
<b>Approximate Dimensions:</b>	
<b>Length</b> . . . . .	1845 mm (72.6 in)
<b>Width</b> . . . . .	1118 mm (44.0 in)
<b>Height</b> . . . . .	1554 mm (61.2 in)

## C9.3 ACERT Power Unit Ratings In-Line 6

<b>A Rating</b> (Continuous)			<b>B Rating</b>			<b>C Rating</b> (Intermittent)		
bkW	bhp	rpm	bkW	bhp	rpm	bkW	bhp	rpm
<b>TA (ATAAC)</b>								
224	300	1800-	242	325	1800-	261	350	1800-
		2200			2200			2200

## Customer Value

- Can be factory-installed with or without radiator
- Can be factory-installed with or without base CEM
- Available for a wide range of ratings
- Factory-validated for high vibration applications

### Abbreviations used:

**TA**.....Turbocharged-Aftercooled

**ATAAC**.....Air-to-Air Aftercooled

### Emissions Regulations for current year

Unless noted, ratings conform with EPA (U.S.) Tier 4 Interim, EU Stage IIIB emission standards.

## C13 ACERT



### Specifications

	<b>C13 ACERT Power Unit</b>
<b>Bore x Stroke</b>	130 x 157 mm (5.1 x 6.18 in)
<b>Displacement</b> . . . .	12.5 liters (762.8 in <sup>3</sup> )
<b>Ship Weight</b> . . . . .	2304 kg (5080 lbs)
<b>Approximate Dimensions:</b>	
<b>Length</b> . . . . .	2085 mm (82.1 in)
<b>Width</b> . . . . .	1157 mm (45.6 in)
<b>Height</b> . . . . .	1573 mm (61.3 in)

### C13 ACERT Power Unit Ratings In-Line 6

TA (ATAAC)	A Rating (Continuous)			B Rating			C Rating (Intermittent)			D Rating			E Rating		
	bkW	bhp	rpm	bkW	bhp	rpm	bkW	bhp	rpm	bkW	bhp	rpm	bkW	bhp	rpm
	287	385	1800-2100	309	415	1800-2100	328	440	1800-2100	354	475	1800-2100	388	520	1800-2100

### Customer Value

- Can be factory-installed with or without radiator
- Can be factory-installed with or without base or standard CEM
- Available for a wide range of ratings
- Factory-validated for high vibration applications

#### Abbreviations used:

TA.....Turbocharged-Aftercooled

ATAAC.....Air-to-Air Aftercooled

#### Emissions Regulations for current year

Unless noted, ratings conform with EPA (U.S.) Tier 4 Interim, EU Stage IIIB emission standards.

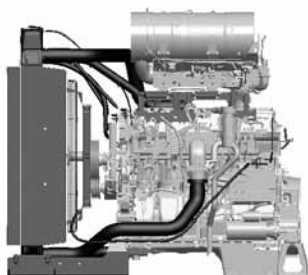

**C15 ACERT**

## Specifications

<b>C15 ACERT Power Unit</b>	
<b>Bore x Stroke</b>	137 x 171 mm (5.39 x 6.73 in)
<b>Displacement . . . .</b>	15.2 liters (927.6 in <sup>3</sup> )
<b>Ship Weight . . . . .</b>	2113 kg (4658 lbs)
<b>Approximate Dimensions:</b>	
<b>Length . . . . .</b>	2172 mm (85.5 in)
<b>Width . . . . .</b>	1180 mm (46.5 in)
<b>Height . . . . .</b>	1912 mm (75.3 in)

## C15 ACERT Power Unit Ratings In-Line 6

<b>A Rating*</b> (Continuous)		<b>B Rating</b>			<b>C Rating</b> (Intermittent)			<b>D Rating</b>			
bkW	bhp	rpm	bkW	bhp	rpm	bkW	bhp	rpm	bkW	bhp	rpm
<b>TA (ATAAC)</b>											
354	475	1800-	354	475	1800-	403	540	1800-	433	580	1800-
		2100			2100			2100			2100

\*Altitude-limited

## Customer Value

- Can be factory-installed with or without radiator
- Can be factory-installed with or without base CEM
- Available for a wide range of ratings
- Factory-validated for high vibration applications

### Abbreviations used:

**TA**.....Turbocharged-Aftercooled

**ATAAC**.....Air-to-Air Aftercooled

### Emissions Regulations for current year

Unless noted, ratings conform with EPA (U.S.) Tier 4 Interim, EU Stage IIIB emission standards.

## C18 ACERT

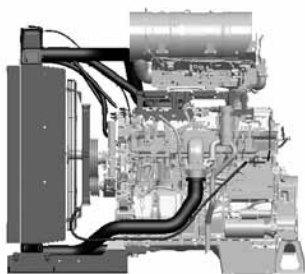

### Specifications

	<b>C18 ACERT Power Unit</b>
<b>Bore x Stroke</b>	145 x 183 mm (5.71 x 7.2 in)
<b>Displacement</b> . . . . .	18.1 liters (1104.5 in <sup>3</sup> )
<b>Ship Weight</b> . . . . .	2113 kg (4658 lbs)
<b>Approximate Dimensions:</b>	
<b>Length</b> . . . . .	2172 mm (85.5 in)
<b>Width</b> . . . . .	1180 mm (46.5 in)
<b>Height</b> . . . . .	1912 mm (75.3 in)

### C18 ACERT Power Unit Ratings In-Line 6

	<b>A Rating*</b> (Continuous)			<b>B Rating</b>			<b>C Rating</b> (Intermittent)		
	<b>bkW</b>	<b>bhp</b>	<b>rpm</b>	<b>bkW</b>	<b>bhp</b>	<b>rpm</b>	<b>bkW</b>	<b>bhp</b>	<b>rpm</b>
<b>TA (ATAAC)</b>	447	600	1800- 1900	447	600	1800- 1900	470	630	1800- 1900

\*Altitude-limited

### Customer Value

- Can be factory-installed with or without radiator
- Can be factory-installed with or without base CEM
- Available for a wide range of ratings
- Factory-validated for high vibration applications
- Factory-installed radiator also available for 522 bkW/700 bhp, 563 bkW/755 bhp, and 597 bkW/800 bhp ratings

#### Abbreviations used:

**TA**.....Turbocharged-Aftercooled

**ATAAC**.....Air-to-Air Aftercooled

#### Emissions Regulations for current year

Unless noted, ratings conform with EPA (U.S.) Tier 4 Interim, EU Stage IIIB emission standards.

## Customer Value

- Advanced NOx Reduction System (NRS) maximizes engine power and fuel efficiency while lowering combustion temperatures and reducing NOx emissions.
- Cat Regeneration System is designed to maximize machine uptime by providing excellent regeneration capability in a variety of environments, with precise measurement and control to reduce fuel burned during regeneration.
- Diesel Oxidation Catalyst (DOC) facilitates passive regeneration and requires no maintenance.
- Diesel Particulate Filter (DPF) reduces Particulate Matter (PM) with its wall-flow design.
- Flexible regeneration options on applicable models maximize fuel efficiency.

**Wall-Flow DPF****Configurations**

	C3.4B	
Approximate Dimensions:	Wall-Flow DPF	Through-Flow DPF
	45-86 bkW (60.3-115.3 bhp)	45-55.4 bkW (60.3-74.3 bhp)
Length .....	541 mm (21.3 in) .....	509 mm (20 in)
Diameter .....	180 mm (7.1 in) .....	149 mm (5.8 in)
Weight .....	20 kg (44 lbs) .....	14 kg (30.8 lbs)

**Customer Value**

- Incorporating low temperature regeneration and with high temperature oxy-exotherm back-up for Wall-Flow DPF
- Extensive range of inlets and outlets, as well as remote and on-engine installations, provide flexibility for many installations.
- Keeping your machines operating without any work cycle interruption

**Standard Emissions Control Equipment**

- **DOC:** Diesel Oxidation Catalyst
- **DPF:** Diesel Particulate Filter
- 3" flex pipe connection kit with straight and 90° options for flexibility

Unless noted, ratings designed to conform with 2012 EPA (U.S.) Tier 4 Interim, EU Stage IIIB emission standards.



## Configurations

	C4.4 ACERT	
	≤82 bkW (110 bhp)	>82 bkW (110 bhp)
<b>Approximate Dimensions:</b>		
<b>Length</b> .....	802.5 mm (32.6 in)	828 mm (32.6 in)
<b>Width</b> .....	365 mm (14.3 in)	365 mm (14.3 in)
<b>Height</b> .....	279 mm (11 in)	300.5 mm (11.8 in)
<b>Weight</b> .....	34 kg (75 lbs)	37 kg (81.6 lbs)
<b>Diameter</b> .....	244.9 mm (9.6 in)	270.3 mm (10.6 in)

## Customer Value

- Low temperature regeneration completely transparent to the operator
- Extensive range of inlets and outlets, as well as remote and on-engine installations, provide flexibility for many installations.
- Service-free DPF for the emissions life of the engine
- Available in 12V or 24V systems

## Standard Emissions Control Equipment

- **DOC:** Diesel Oxidation Catalyst
- **DPF:** Diesel Particulate Filter
- 3" flex pipe connection kit with straight, 45°, and 90° options for flexibility

Unless noted, ratings designed to conform with 2012 EPA (U.S.) Tier 4 Interim, EU Stage IIIB emission standards.



## Configurations

	C6.6 ACERT
<b>Approximate Dimensions:</b>	
<b>Length</b> .....	852.7 mm (33.6 in)
<b>Width</b> .....	364.6 mm (14.35 in)
<b>Height</b> .....	352 mm (13.9 in)
<b>Weight</b> .....	40 kg (88.1 lbs)
<b>Diameter</b> .....	283 mm (11.1 in)

## Customer Value

- Low temperature regeneration completely transparent to the operator
- Extensive range of inlets and outlets, as well as remote and on-engine installations, provide flexibility for many installations.
- Service-free aftertreatment for the emissions life of the engine
- Available in 12V or 24V systems

## Standard Emissions Control Equipment

- **DOC:** Diesel Oxidation Catalyst
- **DPF:** Diesel Particulate Filter
- 3" flex pipe connection kit with straight, 45°, and 90° options for flexibility

Unless noted, ratings designed to conform with 2012 EPA (U.S.) Tier 4 Interim, EU Stage IIIB emission standards.



## Configurations

≤ 172 bkW (231 bhp)  
C7.1 ACERT (Base Configuration)

### Approximate Dimensions:

Length	918.7 mm (36.2 in)
Width	714.4 mm (28.1 in)
Height	618.5 mm (24.3 in)
Weight	124 kg (273.4 lbs)
Diameter	287 mm (11.3 in)

> 172 bkW (231 bhp)  
C7.1 ACERT (Base Configuration)

### Approximate Dimensions:

Length	918.7 mm (36.2 in)
Width	714.4 mm (28.1 in)
Height	643.9 mm (25.3 in)
Weight	134 kg (295.4 lbs)
Diameter	337.8 mm (13.3 in)

**Note:** Final dimensions dependent on configuration

## Options

- **CEM Options Include:**  
Base Aftertreatment Package (DPF/DOC)
- **Multiple Customizable Configuration Options Available:**  
Each option will be available as:
  - 250 mm (10 in) Cat Regeneration System + DOC/DPF [≤172 bkW (231 bhp)]
  - 304.8 mm (12 in) Cat Regeneration System + DOC/DPF

## Customer Value

- Flexible regen options maximize uptime
- Cat Regeneration System maximizes fuel efficiency during regeneration
- Remote installation options provide OEM flexibility for many applications
- Minimum 4500-hour diesel particulate filter ash service interval
- Available in 12V or 24V systems

## Standard Emissions Control Equipment

- **CEM:** Clean Emissions Module
- Cat Regeneration System
- **DOC:** Diesel Oxidation Catalyst
- **DPF:** Diesel Particulate Filter
- **NRS:** NOx Reduction System
- 3" flex pipe connection kit with straight and 90° options for flexibility

Unless noted, ratings conform with EPA (U.S.) Tier 4 Interim, EU Stage IIIB emission standards.

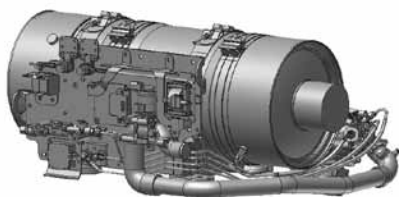

## Configurations

### C9.3 ACERT (Base Configuration)

#### Approximate Dimensions:

Length	1097 mm (43 in)
Width	762 mm (30 in)
Height	468 mm (18 in)
Weight	130 kg (287 lbs)
Diameter	304.8 mm (12 in)

Multiple customizable configuration options available

## CEM Options

- Base configuration includes DPF, DOC, and supporting structure
- Standard configuration includes DPF, DOC, muffler, and supporting structure
- Optional air filter can be attached to CEM standard configuration

## Customer Value

- Cat Regeneration System maximizes fuel efficiency during regeneration
- Flexible regen options maximize uptime  
Flex pipe connection kit with 90° rotatable elbows to attach to Cat Regeneration System Inlet
- Remote installation options provide OEM flexibility for many applications, including horizontal and vertical mounting, with and without muffler
- Minimum 4500-hour diesel particulate filter ash service interval
- Available in 12V or 24V systems

## Standard Emissions Control Equipment

- **CEM:** Clean Emissions Module
- Cat Regeneration System
- **DOC:** Diesel Oxidation Catalyst
- **DPF:** Diesel Particulate Filter
- **NRS:** NOx Reduction System

Unless noted, ratings conform with EPA (U.S.) Tier 4 Interim, EU Stage IIIB emission standards.

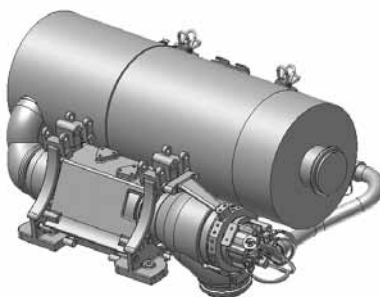

## Configurations

### C13 ACERT (Base Configuration)

#### Approximate Dimensions:

<b>Length</b> .....	1097 mm (43 in)
<b>Width</b> .....	762 mm (30 in)
<b>Height</b> .....	468 mm (18 in)
<b>Weight</b> .....	180 kg (397 lbs)
<b>Diameter</b> .....	330.2 mm (13 in)

Multiple customizable configuration options available

## CEM Options

- Base configuration includes DPF, DOC, and supporting structure
- Standard configuration includes DPF, DOC, muffler, and supporting structure
- Optional air filter can be attached to CEM standard configuration. This option is also available shipped loose for customer-provided mounting.

## Customer Value

- Cat Regeneration System maximizes fuel efficiency during regeneration
- Flexible regen options maximize uptime  
Flex pipe connection kit with 90° rotatable elbows to attach to Cat Regeneration System Inlet
- Remote installation options provide OEM flexibility for many applications, including horizontal and vertical mounting, with and without muffler
- Minimum 4500-hour diesel particulate filter ash service interval
- Available in 12V or 24V systems

## Standard Emissions Control Equipment

- **CEM:** Clean Emissions Module
- Cat Regeneration System
- **DOC:** Diesel Oxidation Catalyst
- **DPF:** Diesel Particulate Filter
- **NRS:** NOx Reduction System

Unless noted, ratings conform with EPA (U.S.) Tier 4 Interim, EU Stage IIIB emission standards.

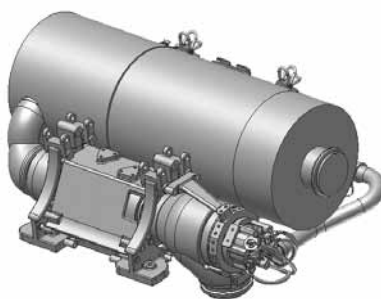

## Configurations

### C15 ACERT (Base Configuration)

#### Approximate Dimensions:

<b>Length</b> .....	1097 mm (43 in)
<b>Width</b> .....	762 mm (30 in)
<b>Height</b> .....	468 mm (18 in)
<b>Weight</b> .....	180 kg (397 lbs)
<b>Diameter</b> .....	330.2 mm (13 in)

Multiple customizable configuration options available

## CEM Options

- Base configuration includes DPF, DOC, and supporting structure
- Standard configuration includes DPF, DOC, muffler, and supporting structure
- Optional air filter can be attached to CEM standard configuration. This option is also available shipped loose for customer-provided mounting.

## Customer Value

- Cat Regeneration System maximizes fuel efficiency during regeneration
- Flexible regen options maximize uptime  
Flex pipe connection kit with 90° rotatable elbows to attach to Cat Regeneration System Inlet
- Remote installation options provide OEM flexibility for many applications, including horizontal and vertical mounting, with and without muffler
- Minimum 4500-hour diesel particulate filter ash service interval
- Available in 12V or 24V systems

## Standard Emissions Control Equipment

- **CEM:** Clean Emissions Module
- Cat Regeneration System
- **DOC:** Diesel Oxidation Catalyst
- **DPF:** Diesel Particulate Filter
- **NRS:** NOx Reduction System

Unless noted, ratings conform with EPA (U.S.) Tier 4 Interim, EU Stage IIIB emission standards.

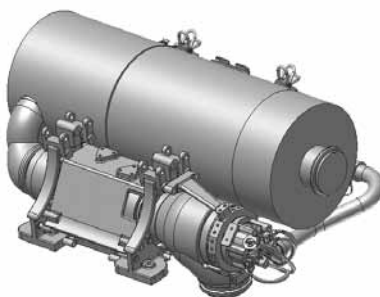

## Configurations

### C18 ACERT (Base Configuration)

#### Approximate Dimensions:

Length	1097 mm (43 in)
Width	762 mm (30 in)
Height	468 mm (18 in)
Weight	180 kg (397 lbs)
Diameter	330.2 mm (13 in)

Multiple customizable configuration options available

## CEM Options

- Base configuration includes DPF, DOC, and supporting structure
- Standard configuration includes DPF, DOC, muffler, and supporting structure
- Optional air filter can be attached to CEM standard configuration. This option is also available shipped loose for customer-provided mounting.

## Customer Value

- Cat Regeneration System maximizes fuel efficiency during regeneration
- Flexible regen options maximize uptime  
Flex pipe connection kit with 90° rotatable elbows to attach to Cat Regeneration System Inlet
- Remote installation options provide OEM flexibility for many applications, including horizontal and vertical mounting, with and without muffler
- Minimum 4500-hour diesel particulate filter ash service interval
- Available in 12V or 24V systems

## Standard Emissions Control Equipment

- **CEM:** Clean Emissions Module
- Cat Regeneration System
- **DOC:** Diesel Oxidation Catalyst
- **DPF:** Diesel Particulate Filter
- **NRS:** NOx Reduction System

Unless noted, ratings conform with EPA (U.S.) Tier 4 Interim, EU Stage IIIB emission standards.

## ACERT™ Technology

- A series of evolutionary, incremental improvements resulting in breakthrough engine technology
- Built on proven Cat systems and components
- Minimizes emissions through better control of the combustion process



## Electronic Control Unit (ECU)

- Electronic engine control unit
- Precise fuel control
- Smarter controller
- Password protected
- Customized engine speed
- Controls idle levels
- Precise injection timing



## Analog Gauge

- 12V and 24V systems
- Liquid Crystal Display: engine hours/diagnostic codes
- 2 LED indicators
- 2- or 3-inch diameter dial
- Thread nut mount installed
- Integral 6-pin Deutsch connector
- Displays engine speed, fuel rate, load percent, pressures, and temperatures



## Control and Display Panels

### Engine Monitoring System Display

- Parameters from engine
- Audible alarm, diagnostic windows
- SAE standard icons
- -40°C to +85°C

### Mini Industrial Panel Display (MIPD)

- 15 user-defined screens
- Max 10 parameters per screen
- 8 displays on same J1939 network
- Multiple language compatibility
- Multiple custom screen options



For additional information visit [www.catelectronics.com](http://www.catelectronics.com)

## Additional Literature

Cat C4.4, C4.4 ACERT, and C6.6 ACERT Engines

Superior Performance and Beyond .....	LEDH6529
Industrial Engine Attachments Guide .....	LEDH6161
Industrial Power Systems Fueled by Innovation .....	LEDH4624
Irrigation Engine Ratings Guide.....	LEDH5378
Commercial Diesel Engine Fluids Recommendations.....	SEBU6251

## Spec Sheets

C0.5 Industrial Engine – 8.2-10.2 kW (11.0-13.7 bhp) .....	LEHH6352
C0.7 Industrial Engine – 12.2-15.3 kW (16.4-20.5 bhp).....	LEHH6361
C1.1 Industrial Engine – 9.5 kW (12.7 bhp) / 11.8 kW (15.8 bhp) / 19.7 kW (26.4 bhp).....	LEHH6351
C1.1 Industrial Engine – 21 kW (28 bhp) .....	LEHH6350
C1.1 Industrial Engine – 13.7-21 kW (18.4-28.2 bhp) .....	LEHH6353
C1.1 Industrial Power Unit – 17.9 kW (24.0 bhp) .....	LEHH6362
C1.5 Industrial Engine – 20.9-25.1 kW (28.0-33.7 bhp) .....	LEHH6354
C1.5 Industrial Engine – 23.1-30.0 kW (31.0-40.2 bhp).....	LEHH6411
C1.5 Industrial Power Unit – 24.2 kW (32.5 bhp) .....	LEHH6355
C1.6 Industrial Engine – 24.6 & 26.5 kW (33 & 33.5 bhp) .....	LEHH6349
C1.7 Industrial Engine – 23.6 & 26.1 kW (31.6 & 35.0 bhp) .....	LEHH6412
C2.2 Industrial Engine – 31.0-38.0 kW (41.6-51.0 bhp) .....	LEHH6356
C2.2 Industrial Engine – 40.0-45.5 kW (53.6-61.0 bhp) .....	LEHH6360
C2.2 Industrial Engine – 49.2 kW (66.0 bhp) .....	LEHH6410
C2.2 Industrial Power Unit – 37.0 kW (49.6 bhp) .....	LEHH8103
C2.2 Industrial Power Unit – 41.7 kW (55.9 bhp) .....	LEHH8104
C4.4 ACERT Industrial Engine – 61.5-129.4 kW (81.8-173.5 bhp) ..	LEHH0021
C6.6 ACERT Industrial Engine – 89-129.5 kW (119.4-173.7 bhp)...	LEHH0022
C7.1 ACERT Industrial Engine – 130-225 kW (175-300 bhp) .....	LEHH0006
C9.3 ACERT Industrial Engine – 224-261 kW (300-350 bhp) .....	LEHH0007
C9.3 ACERT Industrial Power Unit – 224-261 kW (300-350 bhp) ..	LEHH0509
C13 ACERT Industrial Engine – 287-354 kW (385-475 bhp).....	LEHH0008
C13 ACERT Industrial Power Unit – 287-354 kW (385-475 bhp)...	LEHH0510
C15 ACERT Industrial Engine – 354-433 kW (475-580 bhp).....	LEHH0009
C15 ACERT Industrial Power Unit – 354-433 kW (475-580 bhp)...	LEHH0511
C18 ACERT Industrial Engine – 447-522 kW (600-700 bhp).....	LEHH0010
C18 ACERT Industrial Engine – 563 kW (755 bhp) .....	LEHH0513
C18 ACERT Industrial Engine – 563-597 kW (755-800 bhp) Tier 4 Final .....	LEHH0506
C18 ACERT Industrial Power Unit – 447-470 kW (600-630 bhp)...	LEHH0512
C27 ACERT Industrial Engine – 597-783 kW (800-1050 bhp).....	LEHH0011
C32 ACERT Industrial Engine – 709-895 kW (950-1200 bhp).....	LEHH0013



# **Caterpillar. Your Local Resource. Worldwide.**

Your Cat dealer is prepared to answer any questions you may have about Cat Power Systems, customer support, parts or service capability anywhere in the world. For the name and number of the Cat dealer nearest you, visit our website or contact Caterpillar Inc. World Headquarters in Peoria, Illinois, U.S.A.

World Headquarters:  
**Caterpillar Inc.**  
Peoria, Illinois, U.S.A.  
Tel: (309) 578-6298  
Fax: (309) 578-2559

Mailing Address:  
**Caterpillar Inc.**  
Industrial Power Systems  
P.O. Box 610  
Mossville, IL 61552

**[www.cat-industrial.com](http://www.cat-industrial.com)**

**E-mail: [cat\\_power@cat.com](mailto:cat_power@cat.com)**

Materials and specifications are subject to change without notice. Rating ranges listed include the lowest and highest available for a specific engine or family of engines. Load factor and time at rated load and speed will determine the best engine/rating match.

LEGH0001-02 (2-11)  
©2011 Caterpillar  
All rights reserved.

CAT, CATERPILLAR, their respective logos, ACERT, "Caterpillar Yellow" and the "Power Edge" trade dress, as well as corporate and product identity used herein, are trademarks of Caterpillar and may not be used without permission.

