



825

Soil Compactor

Technical Specifications

Configurations and features may vary by region. Please consult your Cat® dealer for availability in your area.

Table of Contents

Specifications	2
Engine	2
Operating Specifications	2
Transmission	2
Hydraulic System	2
Service Refill Capacities	2
Axles	2
Brakes	2
Sound Performance	3
Hydraulic System – Steering	3
Blades	3
Wheels	3
Wheels – High Impact	3
Dimensions	4
Standard and Optional Equipment	5
Environmental Declaration	7

825 Soil Compactor Specifications

Engine		
Engine Model	Cat® C15	
Emissions	U.S. EPA Tier 4 Final/ EU Stage V/Korea Stage V and Japan 2014 or Brazil MAR-1, emitting equivalent to U.S. EPA Tier 3/EU Stage IIIA	
Rated Speed	1,800 rpm	
Net Power (SAE J1349:2011)	302 kW	405 hp
Net Power (ISO 9249:2007)	302 kW	405 hp
Engine Power (ISO 14396:2002)	318 kW	426 hp
Gross Power (SAE J1995:2014)	324 kW	435 hp
Peak Net Torque (1,300 rpm)	2005 N·m	1,479 lbf·ft
Torque Rise	33%	
Bore	137.2 mm	5.4 in
Stroke	171.4 mm	6.7 in
Displacement	15.2 L	927.6 in ³
High Idle Speed	2,300 rpm	
Low Idle Speed	800 rpm	
Maximum Altitude without Derating (U.S. EPA Tier 4 Final/EU Stage V)	2834 m	9,298 ft
Maximum Altitude without Derating (U.S. EPA Tier 3/EU Stage IIIA)	2773 m	9,098 ft

Operating Specifications		
Maximum Operating Weight (Tier 4 Final/ Stage IV)	35 528 kg	78,326 lb
Maximum Operating Weight (Tier 3 Final/ Stage IIIA equivalent)	35 081 kg	77,340 lb

Transmission		
Transmission Type	Planetary – Powershift – ECPC	
Travel Speeds		
Forward – First	5.5 km/h	3.4 mph
Forward – Second	9.7 km/h	6.0 mph
Forward – Third	17.2 km/h	10.7 mph
Reverse – First	6.2 km/h	3.9 mph
Reverse – Second	11.1 km/h	6.9 mph
Reverse – Third	19.7 km/h	12.2 mph

Hydraulic System		
Pump Flow at 1,800 rpm	117 L/min	30.9 gal/min
Main Relief Pressure	26 000 kPa	3,771 psi
Maximum Supply Pressure	24 100 kPa	3,495 psi
Cylinder, Double-acting: Lift, Bore and Stroke	120 mm × 1070 mm	4.7 in × 42.1 in
Cylinder, Double-acting: Tilt, Bore and Stroke	95.25 mm × 215 mm	3.75 in × 8.5 in

Service Refill Capacities		
Cooling System	116 L	30.6 gal
Engine Crankcase	34 L	9.0 gal
Transmission	66 L	17.4 gal
Fuel Tank	782 L	206.6 gal
Diesel Exhaust Fluid Tank (Tier 4 Final/ Stage IV)	32 L	8.5 gal
Differentials and Final Drives – Front	100 L	26.4 gal
Differentials and Final Drives – Rear	110 L	29.1 gal
Hydraulic Tank Only	134 L	35.4 gal

- All non-road Tier 4 Final and Stage V diesel engines are required to use:
 - Ultra Low Sulfur Diesel (ULSD) fuels containing 15 ppm (mg/kg) sulfur or less. Biodiesel blends up to B20 are acceptable when blended with 15 ppm (mg/kg) sulfur or less ULSD and when the biodiesel feedstock meets ASTM D7467 specifications.
 - Cat DEO-ULS™ or oils that meet the Cat ECF-3, API CJ-4, and ACEA E9 specifications are required.
 - Diesel Exhaust Fluid (DEF) that meets all requirements defined in ISO 22241-1:2006.

Axles	
Front	Planetary – Fixed
Rear	Planetary – Oscillating
Oscillation Angle	±8°

Brakes	
Service Brakes	Multi Disc Wet (Enclosed) 2 WHL
Parking Brake	Drum and Shoe, Spring Applied, Hydraulic Released

825 Soil Compactor Specifications

Sound Performance

Tier 4 Final/Stage V	Standard	Suppression
Operator Sound Level (ISO 6396:2008)	73 dB(A)	72 dB(A)
Machine Sound Level (ISO 6395:2008)	113 dB(A)	110 dB(A)
Tier 3/Stage IIIA Equivalent	Standard	Suppression
Operator Sound Level (ISO 6396:2008)	73 dB(A)	72 dB(A)
Machine Sound Level (ISO 6395:2008)	113 dB(A)	110 dB(A)

- The operator sound pressure level was measured according to the test procedures and conditions specified in ISO 6396:2008. The measurement was conducted at 70% of the maximum engine cooling fan speed.
- The machine sound power level was measured according to the test ISO 6395:2008. The measurement was conducted at 70% of the maximum engine cooling fan speed.
- Hearing protection may be needed when operating with an open operator station and cab (when not properly maintained or doors/windows open) for extended periods or in a noisy environment.

Hydraulic System – Steering

Steering System – Circuit	Double Acting – End Mounted	
Bore	114.3 mm	4.5 in
Stroke	576 mm	22.7 in
Steering System – Pump	Piston – Variable Displacement	
Maximum System Flow	170 L/min @ 1,800 rpm	44.9 gal/min @ 1,800 rpm
Steering Pressure Limited	24 000 kPa	3,481 psi
Vehicle Articulation Angle	86 degrees	

Blades

Moldboard Length	4390 mm	14.4 ft
Height Including Cutting Edge	1032 mm	3.4 ft
Maximum Depth of Cut	602 mm	1.97 ft
Maximum Lift Above Ground	958 mm	3.14 ft
Blade Tip Angle – Total	14.8°	
Blade Tip Angle – Forward	7.3°	
Blade Tip Angle – Back	7.5°	
Blade Tilt Angle – Right – Mechanical	5.1°	
Blade Tilt Angle – Left – Mechanical	4.1°	
Blade Tilt Angle – Right – Hydraulic	6.3°	
Blade Tilt Angle – Left – Hydraulic	5.4°	
Blade Tilt Angle – Right Full	10.8°	
Blade Tilt Angle – Left Full	10.1°	
Total Tilt Adjustment	890 mm	2.9 ft
Width Over End Bits	4628 mm	15.18 ft

Wheels

Weight	7333 kg	16,167 lb
Outside Diameter	1672 mm	5 ft 5.8 in
Drum Diameter	1299 mm	4 ft 3.1 in
Drum Width	1125 mm	3 ft 8.3 in
Tips per Wheel	65	
Width over Drums	3650 mm	11 ft 11.7 in

Wheels – High Impact

Weight	7534 kg	16,610 lb
Outside Diameter	1675 mm	5 ft 6 in
Drum Diameter	1299 mm	4 ft 3.1 in
Drum Width	1125 mm	3 ft 8.3 in
Tips per Wheel	65	
Width over Drums	3650 mm	11 ft 11.7 in

825 Soil Compactor Specifications

Dimensions

All dimensions are approximate.

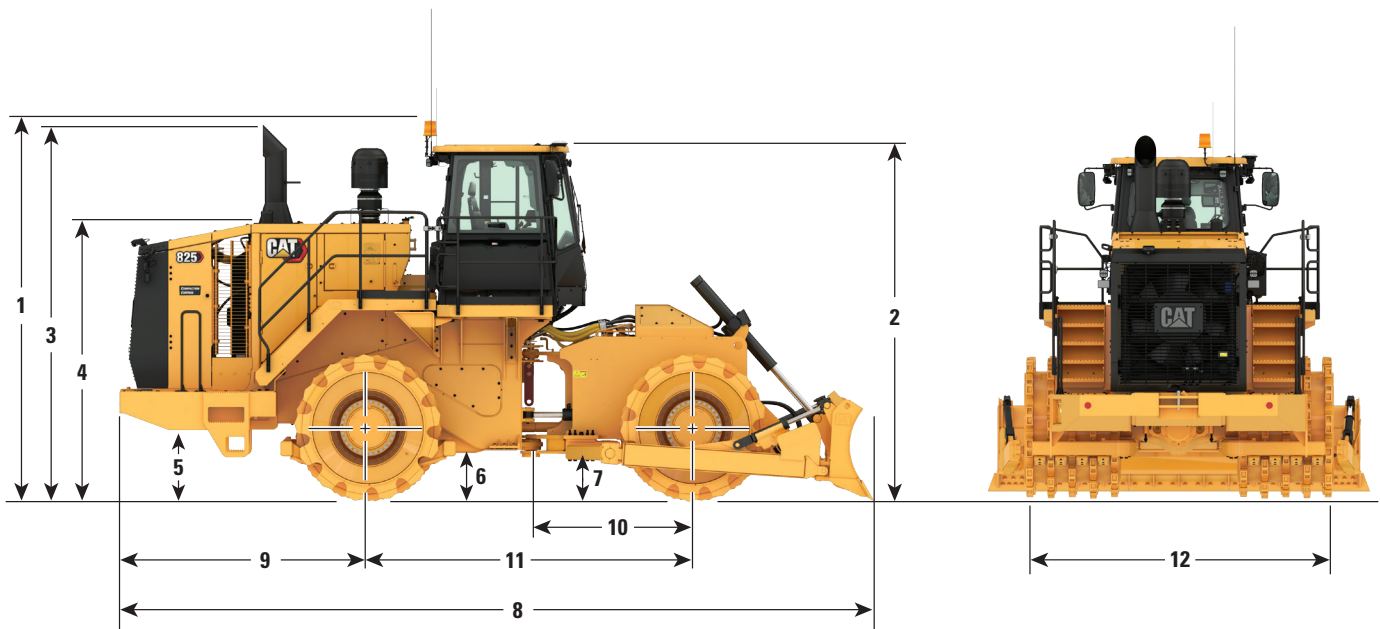

1 Height to Top of Beacon	4381 mm	14 ft 14.5 in
2 Height to Top of Cab	4059 mm	13 ft 3.8 in
3 Height to Top of Exhaust Pipe	4290 mm	14 ft 0.9 in
4 Height to Top of Hood	3162 mm	10 ft 4.5 in
5 Ground Clearance to Bumper	810 mm	2 ft 7.9 in
6 Ground Clearance	492 mm	1 ft 7.4 in
7 Ground Clearance to Trunnion	450 mm	1 ft 5.7 in
8 Length with Blade on Ground (straight blade)	8561 mm	28 ft 1 in
9 Centerline of Rear Axle to Edge of Bumper	2830 mm	9 ft 3.4 in
10 Hitch to Centerline of Front Axle	1850 mm	6 ft 1 in
11 Wheelbase	3700 mm	12 ft 2 in
12 Width over Wheels	3650 mm	11 ft 11.7 in

825 Soil Compactor Standard and Optional Equipment

Standard and Optional Equipment

Standard and optional equipment may vary. Consult your Cat® dealer for details.

	Standard	Optional		Standard	Optional
POWERTRAIN			OPERATOR ENVIRONMENT		
Air-to-air aftercooler	✓		Cab, sound-suppressed pressurized, radio ready for entertainment includes antenna, speakers, converter (12-volt 10/15-amp) and power port	✓	
Axles – standard or non-spin rear		✓	Air conditioner	✓	
Brakes, full hydraulic, enclosed, wet multiple disc service brakes	✓		Cab door, sliding window (LH)	✓	
Cat clean emission module (U.S. EPA Tier 4 Final/EU Stage V only)	✓		Camera, rear vision	✓	
Electro hydraulic parking brake	✓		Cat Compaction Control (ready)	✓	
Electronic clutch pressure control (ECPC)	✓		Cat Detect: object detection (ready)	✓	
Engine, Cat C15 configured for two emissions options: Tier 4 Final/Stage V, or emitting equivalent to Tier 3/Stage IIIA	✓		Coat and hard hat hooks	✓	
Fuel priming pump (electric)	✓		Electro-hydraulic tilt and lift controls	✓	
Fuel-to-air cooler	✓		Fingertip shifting controls	✓	
Ground level engine shutoff	✓		Flip-up armrest	✓	
Heater, engine coolant, 120V		✓	Glass (window) – rubber-mounted glass	✓	
Heater, engine coolant, 240V		✓	Heater and defroster	✓	
Hydraulically driven demand fan	✓		Horn, electric	✓	
Integrated braking	✓		Hydraulic controls – seat mounted	✓	
Muffler under hood (Tier 3/Stage IIIA equivalent only)	✓		Implement hydraulic lockout	✓	
Radiator, aluminum modular radiator (AMR)	✓		Intermittent wipers (front and rear)	✓	
Separated cooling system	✓		Instrumentation, gauges: diesel exhaust fluid (DEF) level (Tier 4 Final/Stage V only), engine coolant temperature, fuel level, hydraulic oil temperature, speedometer/tachometer, torque converter temperature	✓	
Single clutch speed shifting (SCSS)	✓		Instrumentation, warning indicators: action alert system – three categories, brake oil pressure, electrical system – low voltage, engine failure malfunction alert and action lamp, parking brake status	✓	
Starting aid (ether)	✓		Internal four-post rollover protective structure/falling objects protective structure (ROPS/FOPS)	✓	
Throttle lock	✓		Lights, cab – dome	✓	
Torque converter with lockup clutch (LUC)	✓		Lunchbox and beverage holders	✓	
Turbine precleaner, engine air intake	✓		Mirror, internal (panoramic)	✓	
Transmission, planetary with 3F/3R speed range control	✓		Mirrors, standard or heated, rearview (externally mounted)		✓
ELECTRICAL			Precleaner, cab powered	✓	
Alarm, backup	✓		Radio, AM/FM/Aux/USB/Bluetooth®		✓
Alternator, 150 amp	✓		Radio, CB (ready)	✓	
Auxiliary start receptacle	✓		Seat belt with minder, retractable, 76 mm (3") wide	✓	
Batteries, maintenance-free (4-1,000 CCA)	✓		Premium plus seat containing forced air heating and cooling, 2-way thigh adjustment, power lumbar and back bolster adjustment, ride stiffness adjustment, dynamic end dampening, and leather finish	✓	
Electrical system, 24V	✓		Steering and Transmission Integrated Control (STIC™) system with lockout	✓	
Ground level lockable master disconnect switch	✓		Transmission gear (indicator)	✓	
Light, warning switched (LED strobe)	✓		Vital Information Management System (VIMS™): graphical information display, external data port, customizable operator profiles, event indicator light on rear grill	✓	
Lighting, access stairway	✓		Wet-arm wipers/washers (front and rear)	✓	
Lighting system halogen (front and rear)	✓				
Lighting system LED (front and rear)		✓			
Lighting, underhood	✓				
Lights, directional (rear)	✓				
Starter, electric (heavy duty)	✓				

825 Soil Compactor Standard and Optional Equipment

Standard and Optional Equipment

Standard and optional equipment may vary. Consult your Cat dealer for details.

	Standard	Optional		Standard	Optional
GUARDS			OTHER STANDARD EQUIPMENT		
Guards, crankcase and powertrain	✓		Doors, service access (locking)	✓	
Guard, driveshaft	✓		Ecology drains for engine, radiator, transmission, hydraulic tank	✓	
BLADES			Engine idle management features:	✓	
Bulldozer straight blade, hydraulics, and linkage	✓		– Auto idle kickdown		
FLUIDS			– Delayed engine shutdown		
Antifreeze, -50° C (-58° F)		✓	– Engine idle shutdown		
Antifreeze, premixed 50% concentration extended life (-34° C/-29° F)	✓		Engine, crankcase, 500 hour interval with CJ-4 oil	✓	
TECHNOLOGY PRODUCTS			Emergency platform egress	✓	
Product Link™ – Cellular, Satellite	✓		Fire suppression ready	✓	
Compaction control, basic		✓	Fold down exhaust stack for shipping	✓	
WHEELS AND CLEANER BARS			Fuel tank, fast fill, 782 L (207 gal)	✓	
Wheels, tamping foot	✓		Hitch, drawbar with pin	✓	
Wheels, high impact		✓	Hoses, Cat XT™	✓	
Cleaner bars with teeth	✓		Hydraulic, engine, and transmission oil coolers	✓	
			Oil change system, high speed	✓	
			Oil sampling valves	✓	
			Stairways, fixed–L/R (rear access)	✓	
			Steering, load sensing	✓	
			Total hydraulic filtration system	✓	
			Vandalism protection caplocks	✓	
			Venturi stack	✓	
			SPECIAL ARRANGEMENTS		
			Engine precleaners – single stage	✓	
			Engine precleaners – dual stage		✓
			Engine, sound suppression		✓
			MISCELLANEOUS		
			CE/UKCA Certification (standard where regulations require it)		✓
			Plate – year of manufacture		✓

825 Soil Compactor Environmental Declaration

The following information applies to the machine at the time of final manufacture as configured for sale in the regions covered in this document. The content of this declaration is valid as of the date issued; however, content related to machine features and specifications are subject to change without notice. For additional information, please see the machine's Operation and Maintenance Manual.

For more information on sustainability in action and our progress, please visit <https://www.caterpillar.com/en/company/sustainability>.

Engine

- The Cat® C15 engine is available in two engine emission configurations. One meets U.S. EPA Tier 4 Final, EU Stage V, Korea Stage V, and Japan 2014 emissions standards. The other meets Brazil MAR-1, emitting equivalent to U.S. EPA Tier 3 and EU Stage IIIA.
- Cat U.S. EPA Tier 4 Final, EU Stage V, Korea Stage V, and Japan 2014 diesel engines are required to use ULSD (ultra-low sulfur diesel fuel with 15 ppm of sulfur or less) or ULSD blended with the following lower-carbon intensity fuels up to:
 - ✓ 20% biodiesel FAME (fatty acid methyl ester)*
 - ✓ 100% renewable diesel, HVO (hydrotreated vegetable oil) and GTL (gas-to-liquid) fuels
- Cat engines meeting Brazil MAR-1, emitting equivalent to U.S. EPA Tier 3 and EU Stage IIIA, are compatible with diesel fuel blended with the following lower-carbon intensity fuels up to:
 - ✓ 100% biodiesel FAME (fatty acid methyl ester)**
 - ✓ 100% renewable diesel, HVO (hydrotreated vegetable oil) and GTL (gas-to-liquid) fuels

Refer to guidelines for successful application. Please consult your Cat dealer or "Caterpillar Machine Fluids Recommendations" (SEBU6250) for details.

**Engines with no aftertreatment devices can use higher blends, up to 100% biodiesel.*

***For use of blends higher than 20% biodiesel, consult your Cat dealer.*

Air Conditioning System

- The air conditioning system on this machine contains the fluorinated greenhouse gas refrigerant R134a (Global Warming Potential = 1430). The system contains 2.0 kg (4.4 lb) of refrigerant which has a CO₂ equivalent of 2.86 metric tonnes (3.15 tons).

Paint

- Based on best available knowledge, the maximum allowable concentration, measured in parts per million (PPM), of the following heavy metals in paint are:
 - Barium < 0.01%
 - Cadmium < 0.01%
 - Chromium < 0.01%
 - Lead < 0.01%

Sound Performance

Tier 4 Final/Stage V	Standard	Suppression
Operator Sound Level (ISO 6396:2008)	73 dB(A)	72 dB(A)
Machine Sound Level (ISO 6395:2008)	113 dB(A)	110 dB(A)
Tier 3/Stage IIIA Equivalent	Standard	Suppression
Operator Sound Level (ISO 6396:2008)	73 dB(A)	72 dB(A)
Machine Sound Level (ISO 6395:2008)	113 dB(A)	110 dB(A)

- The operator sound pressure level was measured according to the test procedures and conditions specified in ISO 6396:2008. The measurement was conducted at 70% of the maximum engine cooling fan speed.
- The machine sound power level was measured according to the test ISO 6395:2008. The measurement was conducted at 70% of the maximum engine cooling fan speed.
- Hearing protection may be needed when operating with an open operator station and cab (when not properly maintained or doors/windows open) for extended periods or in a noisy environment.

Oils and Fluids

- Caterpillar factory fills with ethylene glycol coolants. Cat Diesel Engine Antifreeze/Coolant (DEAC) and Cat Extended Life Coolant (ELC) can be recycled. Consult your Cat dealer for more information.
- Cat Bio HYDO™ Advanced is an EU Ecolabel approved biodegradable hydraulic oil.
- Additional fluids are likely to be present, please consult the Operations and Maintenance Manual or the Application and Installation guide for complete fluid recommendations and maintenance intervals.

Features and Technology

- The following features and technology may contribute to fuel savings and/or carbon reduction. Features may vary. Consult your Cat dealer for details.
 - Engine idle management system and auto engine idle shutdown reduce idle RPM and maximize fuel efficiency
 - Autoshift mode to automatically upshift or downshift based on machine speed, optimizing performance and conserving fuel
 - Load sensing hydraulic steering system enables precise machine control for easier loading
 - Extended maintenance intervals reduce fluid and filter consumption
 - Cat torque converter with lock-up clutch improves travel speeds, optimizes fuel efficiency, and eliminates torque converter losses, while lowering system heat

ZEPPELIN IN IHRER NÄHE

Mit unseren rund 40 Niederlassungen in Deutschland und Österreich sind wir immer in der Nähe Ihres Standortes oder Ihrer Baustelle. Der Zeppelin Service steht Ihnen rund um die Uhr zur Verfügung. Wir liefern 98 % aller Ersatzteile innerhalb von 24 Stunden.

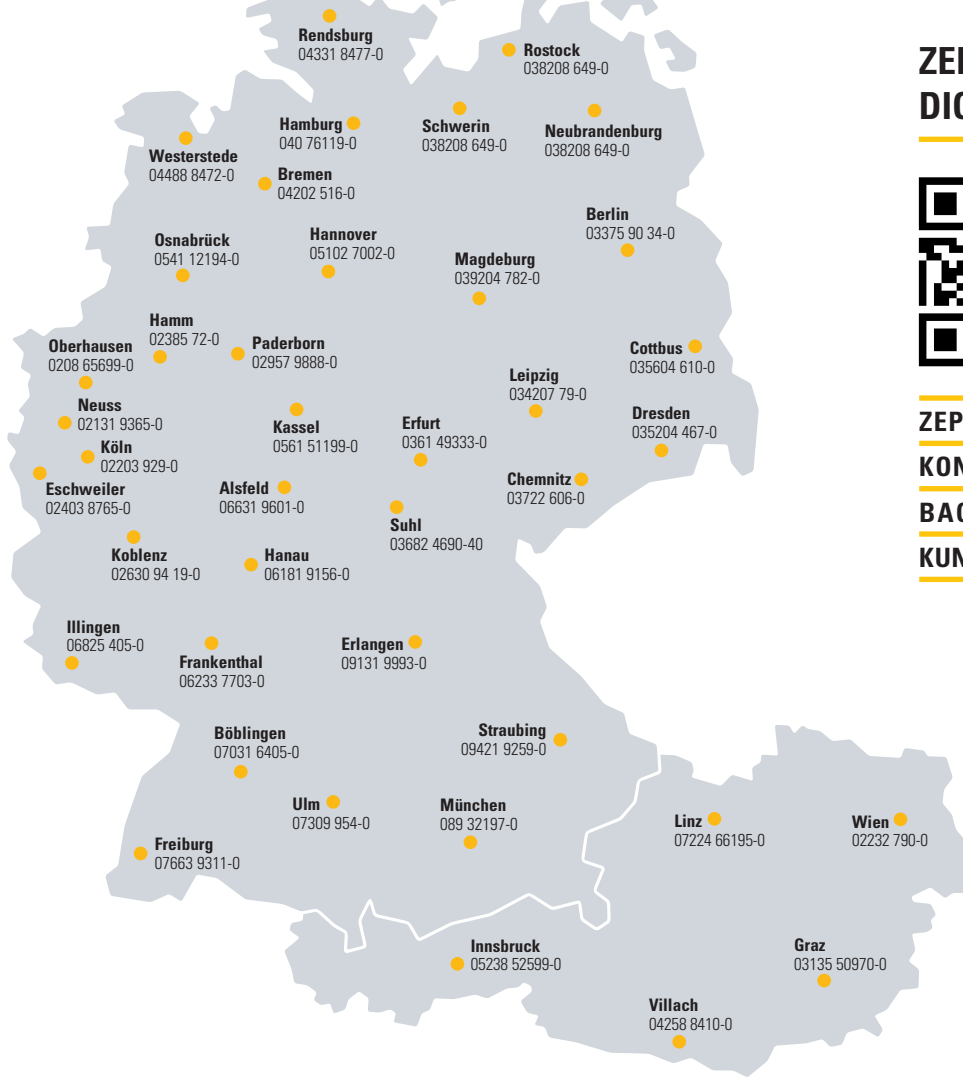

ZEPPELIN DIGITAL



- ZEPPELIN SHOP
- KONFIGURATOR
- BAGGERBÖRSE
- KUNDENPORTAL



Günstige Finanzierungen für alle unsere Maschinen über unseren Partner Cat Financial.
Schnell. Einfach. Flexibel. Individuell.

Zeppelin Baumaschinen GmbH
Graf-Zeppelin-Platz 1 · 85748 Garching bei München
Tel. 089 32000-0 · zeppelin-cat@zeppelin.com
zeppelin-cat.de

Zeppelin Österreich GmbH
Zeppelinstraße 2 · 2401 Fischamend bei Wien
Tel. 02232 790-0 · info.at@zeppelin.com
zeppelin-cat.at

For more complete information on Cat products, dealer services, and industry solutions, visit us on the web at www.cat.com.

AEXQ3690-00 (03-2024)
Build Number: 11A
Global

Materials and specifications are subject to change without notice. Featured machines in photos may include additional equipment. See your Cat dealer for available options.

© 2024 Caterpillar. All Rights Reserved. CAT, CATERPILLAR, LET'S DO THE WORK, their respective logos, DEO-ULS, HYDO, VIMS, Product Link, XT, STIC, "Caterpillar Corporate Yellow", the "Power Edge" and Cat "Modern Hex" trade dress as well as corporate and product identity used herein, are trademarks of Caterpillar and may not be used without permission.

